

Gas Appliances and Gas Piping

Manual Owner: William Flannelly

REV 3.02

January 10, 2024

This Page Intentionally Blank

Record of Revisions

Revision Number	Revision Date	Sections Revised	Reason for Revision
REV 1.00	September 1, 2010	All	New Manual
REV 1.01	February 29, 2012	Chapter 2	Chapter 2 – Updated Section 2.2 and 2.4. Added new Section 2.3 and 2.4.1.
REV 1.02	July 6, 2012	Chapter 3	Chapter 3 – All copper pipe references and sizing tables are removed. Updated Sections 1, 2.1, 2.2, 2.3, Figures 3.1 and 3.2. Removed Section 2.3 and 3.
REV 1.03	February 28, 2014	TOC, LOF, Chapter 2, 4 and 7	Chapter 2 – Added Section 8. Natural Gas Odorant – Safety Information Chapter 4 – Updated Section 3.3. Chapter 7 – Added Section 1. Ladder Safety. Added Figures 7.1, 7.4, 7.8, 7.10 and 7.12. Updated Sections 2.4, 3. and 3.5 and Figures 7.6, 7.7, 7.8 and 7.9 Renumbered subsequent sections, and figures. Updated cross references.
REV 1.04	September 30, 2015	Chapters 2, 4, 5 and 8	Chapter 2 – Updated Section 2.2 and, title and notes of Figure 2.1. Chapter 4 – Updated Section 2.1, # 2 c – Attic Installations ii and iii. Chapter 5 – Updated Section 2.3, # 3 and Section 2.4 # 3. Chapter 8 – Table 8-1 – Added International Plumbing Code (IPC) Section 504.6 reference for PRV discharge piping in “Relief Valve and Piping” inspection item covered under Steam Heating Systems and Forced Hot Water Heating Systems categories.
REV 1.05	February 28, 2016	Chapters 2, 5 and 8	Chapter 1 – Section 7.2 – Revise HTNP Pressure Requirements Chapter 5 – Sections 2.3 #3 and 2.4 #3 – Insert NPC Reference 10.6.16 for Pressure Relief Valve Chapter 8 – Revised Table 8-1 to add National Plumbing Code (NPC) Section 10.6.16 reference for PRV discharge piping in "Relief Valve and Piping" inspection item covered under Steam Heating Systems and Forced Hot Water Heating Systems categories.
REV 2.00	August 1, 2016	All Chapter 2	Complete cover to cover review. Chapter 2 – Update of Section 2.2 and 2.3, regulator vent terminus revision.
REV 2.01	March 15, 2017	Chapter 1	Chapter 1 – Updated all Section 7 – Meter Outlet Pressure
REV 2.02	August 31, 2018	Introduction, Chapters 1 and 2	Introduction – Updated Sections 3 and 9. Chapter 1 – Updated Section 3. Chapter 2 – Updated Section 2.4.
REV 2.03	November 15, 2019	Title page, TOC, Introduction and Chapter 2	Introduction – Updated Sections 2 and 9. Chapter 2 – Added new Section 2 – Piping Requirements and renumbered subsequent sections. Updated Sections 6.1, 6.6 and 6.7.

Revision Number	Revision Date	Sections Revised	Reason for Revision
REV 2.04	August 21, 2020	Title page, TOC, LOF, List of Forms Chapters 1, 2 and 3.	<p>Added List of Forms</p> <p>Chapter 1 – Clarification of Standard and Higher than Normal Delivery Pressures in Section 7.1 and 7.2. Removed references to copper in Sections 7.2 and 7.3. Added form GS-AS-GAP-Form001 to end of chapter.</p> <p>Chapter 2 – Section 2 – Added IFGC requirement and reasons why PSE&G cannot allow copper and removed note prohibiting use of pressfit technology. Clarifications Regarding Customer-Owned Underground Gas Piping in Section 6. Removed references to copper in Sections 6.3 and 6.4. Removed references to copper in Sections 6.3 and 6.4.</p> <p>Chapter 3 – Updated guidelines for Flexible Tubing (CSST) in Section 1.1. Removed references to copper in Section 2.2.</p> <p>Added Forms chapter.</p>
REV 2.05	March 23, 2021	Title page, TOC, LOF, LOT, Introduction and Chapter 2	<p>Chapter 2 – Clarification of IMR Regulator Tag Location in Section 3.3.</p> <p>Updated Section 3.4.1 – Meter Set Protection Guidelines (define materials/ construction for bollards, concrete pad and added new Figure 2-6: Installation of Meter Set Warning Device)</p>
REV 3.00	August 25, 2021	All	<p>5 year cover-to-cover review completed.</p> <p>Chapter 3 – Corrected instances of CCST to CSST.</p> <p>Chapter 4 – Updated dimensions for access to attic installations in Section 2.1.2.c.ii.</p> <p>Chapter 9 – Removed regions and added Northern and Southern Counties.</p>
REV 3.01	October 4, 2021	Title page and Chapter 4	<p>Chapter 4 – Updated dimensions for access to attic installations in Section 2.1.2.c.ii. back to 20 x 30 inches.</p>
REV 3.02	January 10, 2024	Title page and Introduction	<p>Changed Manual Owner to William Flannelly – Manager Technical Support.</p>

Table of Contents

List of Figures	xi
List of Tables	xiii
List of Forms	xv
Introduction	xvii
1. Installation of Gas Appliances and Gas Piping	xvii
2. Overview	xvii
3. Safety	xvii
4. New Format	xviii
5. Latest Version	xviii
6. Updates	xviii
7. How to Use this Manual	xix
8. Symbols	xx
9. What's New	xx
10. Ownership and Confidentiality	xx
Chapter 1 – General Information	1-1
1 Scope	1-1
1.1 Applicability	1-1
1.2 Other Standards	1-1
1.3 Responsibility	1-1
1.4 Use of the Words “Shall” and “Should”	1-1
2 Gas Supply and Service	1-1
2.1 Tightness of Piping System	1-1
2.2 Requirements for Gas Meter Installation	1-2
2.3 Hazardous Appliances or Installation	1-2
2.4 Appliance Service	1-2
3 Disconnection of Meters	1-2
4 Installation of Additional Appliances	1-2
5 Heating and Air Conditioning Appliances	1-2
5.1 Availability of Gas Service	1-2
5.2 Inspection	1-3
5.3 Violations	1-3

5.4	Installer Responsibility	1-3
6	Services	1-3
6.1	Application for Service	1-3
6.2	Location of Service	1-3
6.3	Service Entrance	1-3
7	Meter Outlet Pressure	1-4
7.1	Normal Meter Outlet Pressure	1-4
7.2	Higher Than Normal Meter Outlet Pressure (HTNP)	1-4
7.3	Pressure Testing Requirements	1-5
Chapter 2 – Gas Piping Installation		2-1
1	Piping Plan	2-1
2	Piping Requirements	2-1
3	Provisions for Meter Location	2-1
3.1	Location – Outdoors	2-2
3.2	Prohibited Outside Meter Set Locations – New Installations	2-2
3.3	Prohibited Outside Meter Set Locations – Existing	2-5
3.4	Meter Set Protection	2-6
3.5	Location – Indoors	2-10
3.6	Marking at Multiple Meter Installations	2-10
4	Interconnections	2-10
4.1	Interconnections Supplying Separate Customers	2-10
4.2	Interconnections for Stand-By Fuels	2-10
5	Size of Piping to Gas Appliances	2-10
5.1	Size of Supply Piping for Gas Appliances	2-10
5.2	Allowable Pressure Drop	2-10
5.3	Diversity Factor	2-11
5.4	Additions to Existing Gas Piping	2-11
6	Underground Gas Piping	2-11
6.1	General	2-11
6.2	Use of Plastic Piping	2-12
6.3	Material Specifications	2-12
6.4	Approved Pipe Joining Methods	2-12
6.5	Underground Corrosion Control	2-12
6.6	Notification and Permits	2-12

6.7	Pressure Test	2-13
7	Underground Plastic Piping Installations.	2-13
7.1	Plastic Piping Materials	2-13
7.2	Plastic Rated Sizes	2-13
7.3	Plastic Tubing and Piping Size	2-14
7.4	Storage and Handling	2-14
7.5	Installation	2-14
7.6	Piping Through Foundation Wall	2-15
7.7	Joining the Plastic Pipe	2-15
8	Flexible Tubing Systems	2-16
8.1	General.	2-16
9	Natural Gas Odorant – Safety Information.	2-16
Chapter 3 – Guidelines for Flexible Tubing (CSST) – Natural Gas Systems		3-1
1	System Design	3-1
1.1	General Description	3-1
1.2	Tubing and Manifold System Components	3-1
1.3	Tubing Sizing Procedure	3-5
1.4	Examples	3-5
1.5	Low Pressure System	3-11
2	Installation Practices	3-11
2.1	General Guidelines	3-11
2.2	Identification (Labeling)	3-12
2.3	Protection.	3-12
2.4	Pressure Testing and Inspection Procedure	3-15
Chapter 4 – Appliance Installation		4-1
1	General	4-1
1.1	Appliances, Accessories and Equipment to be “Approved”	4-1
1.2	Type of Gas	4-1
1.3	Gas Pressure Booster.	4-1
1.4	Back Pressure Protection	4-1
1.5	Flammable Vapors or Dusts and Halogenated Hydrocarbons.	4-1
1.6	Air for Combustion and Ventilation	4-2
2	Accessibility and Clearance	4-2

2.1	Accessibility for Service	4-2
2.2	Access to Suspended Gas Appliances	4-10
3	Appliances on Roofs	4-10
3.1	General	4-10
3.2	Installation	4-11
3.3	Access to Appliances	4-11
3.4	Accessibility for Servicing	4-12
Chapter 5 – Installation of Specific Appliances		5-1
1	General	5-1
1.1	Multiple Appliances	5-1
1.2	Continuous Power	5-1
2	Central Heating Boilers and Furnaces	5-1
2.1	Equipment Sizing Procedure	5-1
2.2	Forced Warm Air Heating Systems	5-1
2.3	Steam Heating Systems	5-2
2.4	Hot Water Heating Systems	5-5
2.5	Refrigeration Coils	5-6
2.6	Masonry Chimneys	5-6
3	Gas Ranges	5-6
3.1	Anti-Tipping Devices	5-6
Chapter 6 – Single-family Heating Equipment Input Requirements		6-1
Chapter 7 – Construction Specifications – Suspended and Roof Installed Appliances		7-1
1	Ladder Safety	7-1
1.1	Ladder Condition	7-1
2	Access to Suspended Appliances	7-2
2.1	Fixed Platforms	7-2
2.2	Stairways	7-2
2.3	Mobile Stands or Scaffolds	7-2
2.4	Fork Lift Platforms	7-5
2.5	Ladders	7-7
3	Access to Appliances on Roofs	7-11
3.1	Stairways and Ramps	7-11
3.2	Portable Ladders	7-11

3.3	Caged Ladders	7-11
3.4	Guard Rails	7-12
3.5	Care and Use of Ladders	7-16
	Chapter 8 – Standardized Inspection Checklist	8-1
	Chapter 9 – PSE&G Construction Inquiry Center	9-1
	Forms	Form-1

This Page Intentionally Blank

List of Figures

Figure 1.1: Sample of Request for Higher Than Normal Pressure – Page 1 of 2 (GS-AS-GAP-Form001)	1-6
Figure 1.2: Sample of Request for Higher Than Normal Pressure – Page 2 of 2 (GS-AS-GAP-Form001)	1-7
Figure 2.1: Regulator Vent Terminus Clearances from Building Openings	2-3
Figure 2.2: Outside Meter Set Clearances Under an Elevated Deck	2-4
Figure 2.3: Outside Meter Set Clearance from Electric Meters or Disconnects	2-5
Figure 2.4: IM Tag 95-0588	2-6
Figure 2.5: Outside Meter Set Clearances from Driveway or Parking Area	2-8
Figure 2.6: Installation of Meter Set Warning Device (Bollard)	2-9
Figure 3.1: Parallel Branch Arrangements	3-2
Figure 3.2: Optimized Parallel Arrangements	3-2
Figure 3.3: Tubing Manifold System Components	3-4
Figure 3.4: Illustration for Example #1	3-6
Figure 3.5: Illustration for Example #2	3-9
Figure 3.6: Construction Requiring Protection (Wall)	3-14
Figure 3.7: Construction Requiring Protection (Ceiling)	3-14
Figure 4.1: Examples of Minimum Basement or Utility Room Clearances	4-5
Figure 4.2: Examples of Minimum Basement or Utility Room Clearances (2)	4-6
Figure 4.3: Examples of Minimum Crawl Space Clearances	4-7
Figure 4.4: Examples of Minimum Crawl Space Clearances (2)	4-8
Figure 4.5: Examples of Minimum Attic Clearances	4-9
Figure 5.1: Examples of Hartford Equalizer Connections	5-4
Figure 7.1: Defective Equipment Tag (PSE&G Form 95-5454)	7-1
Figure 7.2: Suspended Unit Accessing Using Stairway or Ladder Terminating at a Platform	7-4
Figure 7.3: Forklift Platforms	7-6
Figure 7.4: 4 to 1 Ladder Rule	7-7
Figure 7.5: Portable Ladders	7-9
Figure 7.6: Fixed Ladders	7-10
Figure 7.7: Outside Access to Roof Using Portable Ladders with Supports	7-12
Figure 7.8: Roof Access Using Extension Ladder	7-13
Figure 7.9: Inside Access to Roof Using Portable Ladder with Supports	7-14
Figure 7.10: Caged Ladder	7-15
Figure 7.11: Installation on Roofs that Have No Parapet and Require Railings	7-16
Figure 7.12: Safety Belt with Two D-Rings	7-18

This Page Intentionally Blank

List of Tables

Table 2-1: Specifications for High Density PE4710 Plastic Tubing	2-13
Table 2-2: Specifications for High Density PE4710 Plastic Tubing	2-13
Table 2-3: Capacity of Plastic Tubing and Pipe in Cubic Feet Per Hour.	2-14
Table 3-1: Sizing Table for Example #1.	3-7
Table 3-2: Sizing Table for Example #2.	3-10
Table 5-1: Boiler Input Rating vs Size of Header.	5-3
Table 5-2: Boiler Input Rating vs Size of Equalizer	5-3
Table 6-1: Single-family Heating Equipment Input Requirements.	6-1
Table 8-1: Gas Appliance Installation Requirements.	8-1

This Page Intentionally Blank

List of Forms

[GS-AS-GAP-Form001](#) – Request for Higher Than Normal Pressure (for a fillable form click [here](#)).

This Page Intentionally Blank

Introduction

1. Installation of Gas Appliances and Gas Piping

The specifications in this manual are a supplement to the *International Fuel Gas Code* and in some cases these specifications differ from the provisions of the foregoing standard. These differences are necessitated by experience based on local conditions and are intended to further ensure that the customer will be provided with safe and efficient operation of their gas appliances.

In accordance with Company policy and with the regulations of PSE&G's tariff filed with the New Jersey Board of Public Utilities, PSE&G will not furnish gas service to any installation which PSE&G believes to be improper or unsafe.

As has been indicated by the New Jersey Department of Community Affairs, the inspection of gas installations is a cooperative effort by the local code enforcement official and the natural gas supplier.

If cases arise where additional information is required, contact the local Marketing Services District Office. An address list is provided in [Chapter 9](#) of this manual.

2. Overview

The Manual Owner for the *Gas Appliances and Gas Piping* manual is William Flannelly – Manager Technical Support. Any content questions and/or suggestions for revisions should be directed to him. This manual has been established to provide guidance on material and methods to be utilized in the maintenance and operations pertaining to the *Gas Appliances and Gas Piping* manual, Gas Delivery. It is expected that deviations from these guidelines shall have prior approval of the Manager Technical Support – Appliance Service, Electric & Gas Asset Strategy, so that safety and consistency will be maintained.

This manual was redesigned and revised in 2024 and replaces all previous versions. It has been updated and rewritten to include current practices, procedures, and technologies to present the information in a practical format that can be easily accessed and followed by all PSE&G Personnel. It is not intended that this manual is a stand-alone document, but should be complemented with Original Equipment Manufacturers (OEM) documentation and other Technical Manuals (e.g., *PSE&G Safety Standards and Procedures*), as required.

3. Safety

Each Chapter of this manual incorporates worker safety in all operational procedures. All personnel performing Gas Operations or Appliance Service work are expected to be fully informed of all safety rules and procedures and strict adherence is mandatory.

It is not intended that these standards replace any governmental regulations, codes, or ordinances. In conforming to these standards, all company safety standards, regulations, procedures, practices and sound judgment shall be followed.

The entire manual has been updated based on the many years of experience of key Subject Matter Experts (SME) in Company operations and the recommendations and requirements of recognized safety associations and authorities. Additional safety procedures will occasionally be issued, either verbally or in writing, and are considered an extension of the practices contained in this manual.

Since specific safety rules cannot cover all conditions that may arise on the job, each associate has a primary responsibility to follow the instructions contained in this manual, to be alert and to use good judgment for their own safety, the safety of their fellow workers and the general public. More detailed safety information can be found in the *PSE&G Safety Standards and Procedures* manual at [PSE&G OEM Document Warehouse](#).

4. New Format

A new format has been created for the Technical Manuals to:

- Make them more user friendly
- Have a consistent format across all Technical Manuals
- Create larger graphics and drawings
- Make them easier to read
- Make them compatible with our electronic requirements for posting on our website
- Make them easily adaptable to PDF files and therefore easier to search.

5. Latest Version

All Technical Manuals and Procedures are available electronically and are the “**latest**” or “**most current**” version. These PDF files can be accessed 24 hours, 7 days per week at the [PSE&G OEM Document Warehouse](#) and can all be printed out. Drawings can be enlarged. They are easy to navigate through “bookmarks” on the left hand side of the page – you can click on each chapter to take you there. You can also search them for your key interests and topics by using the **Search Tool** on the top of the menu bar.

6. Updates

It is recognized that updates and/or modifications to this manual will be required as new equipment, ideas and procedures are developed in PSE&G. Such updates and/or modifications or change requests shall be initiated and approved by the Manual Owner and/or their Subject Matter Experts and submitted to the Technical Documentation area. You can also use our TechManuals@pseg.com email address to inquire about possible changes that we will direct to the Manual Owners. All users are encouraged to give their feedback on this manual and its content at any time. The Technical Documentation Department of PSE&G shall implement any and all changes only upon receipt of the approval of the Manual Owner. These changes will then be effected by revising or replacing existing pages or by issuing a bulletin to ensure uniform application for appropriate associates. When new or revised pages are complete, they shall be inserted in their proper places in the manuals. Notification to all applicable personnel will also take place upon approval of the Manual Owner in a prompt and timely manner. Our electronic versions online at the [PSE&G OEM Document Warehouse](#) will reflect our most current revisions.

The distribution of any changes is controlled by the Manual Owner and implemented by the Technical Documentation Department.

7. How to Use this Manual

Each manual consists of the following components:

- Cover page – shows the Manual Owner and Date of Release
- Record of Revisions
- Table of Contents
- List of Figures (all drawings/photographs/specifications)
- List of Tables
- Chapters
- Tabs marking the beginning of all Chapters
- Each page lists, in the footer, the revision date of that page (bottom inside margin) and the Chapter/Part of the manual to which this page refers (bottom outside margin). Also, where a Section Letter was used previously instead of a Chapter Number, this Section and Letter are indicated at the top of each page. For example, Chapter 3 (old Section C) will be at the top.
- Each drawing is a specific Figure Number as is each Table. All references throughout the manual refer to these figures/tables.
- References will appear in the manual in two formats:

a. Internal References

Internal references are references to topics that are in other locations of the *Gas Appliances and Gas Piping* manual. These references will list the Chapter number (if applicable) and Section number and will link to the referenced material.

b. External References

External references are references to topics that are located in other manuals. These references will appear in the following format:

Manual Title: Chapter Title; Section Title (if applicable); Sub-Section Title (if applicable)

Example:

Service Instruction Manual: Safety; Eye Protection

- References will also appear in the following format and may be internal or external references.

Reference



- Appliances on Roofs: Chapter 4., Section 3
- *Service Instruction Manual*: Safety; Eye Protection

8. Symbols

The following symbols are used throughout the manual to direct the reader to important topics.

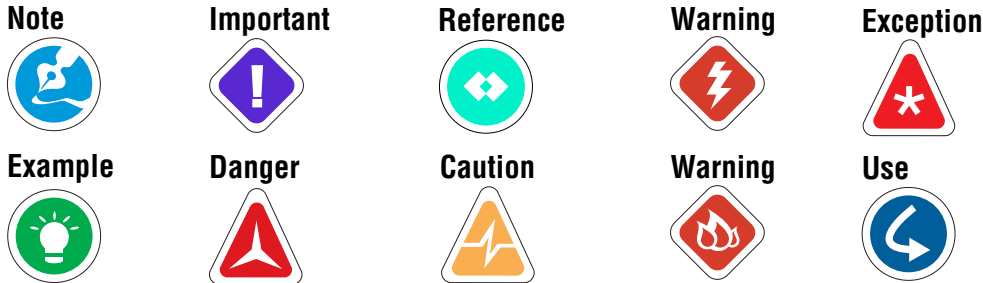

9. What's New

The following are the sections that have been expanded, added or changed for this revision:

- Change the Manual Owner to William Flannelly, Manager Technical Support.

10. Ownership and Confidentiality

The *Gas Appliances and Gas Piping* manual is the property of PSE&G. The Manual Owner is William Flannelly – Manager Technical Support. **It is a confidential document for PSE&G personnel only.** It is loaned to you subject to recall without prior notice, and with the distinct understanding that it is to be used only for the duration of and in connection with the performance of work for PSE&G. Reproduction in whole or in part is expressly forbidden. Should any circumstances arise under which you will no longer require this manual for the specific purpose for which it is loaned to you, it must be returned promptly. Under no circumstances shall this manual be transferred, loaned or by any other means made available to any other individual outside the Company, firm or corporation without the express written permission of the Manual Owner.

We welcome any comments or feedback – please contact the Technical Documentation Department.
TechManuals@pseg.com.

Chapter 1 – General Information

1 Scope

1.1 Applicability

This manual is a supplement to the *International Fuel Gas Code*. This Code offers general criteria for the installation, operation, maintenance of gas piping and gas equipment on consumers' premises and is endorsed by PSE&G Company.

In applying these criteria, reference should be made to the manufacturer's instructions, the State *Uniform Construction Code (UCC)* and the *BOCA Mechanical Code*. Where the International Fuel Gas Code is less restrictive than any of these instructions or codes, the more restrictive provisions shall take precedence.

1.2 Other Standards

Other reference standards endorsed by PSE&G Company for the installation of specific equipment and accessories are found in the *International Fuel Gas Code*, Chapter 6: Referenced Standards.

1.3 Responsibility

PSE&G will assume no responsibility for the condition of the customer's gas installation or for accidents, fires, or failures which may occur as the result of the condition of such gas installation.

Neither by recommendations provided, inspection or non-rejection, nor in any other way, does PSE&G give any warranty, expressed or implied, as to the workmanship, adequacy, safety, or other characteristics of any structure, equipment, wires pipes, appliances, or devices used by the customer.

1.4 Use of the Words “Shall” and “Should”

Use of the word “shall” in these standards is intended to indicate a requirement which must be complied with in full. Failures to comply with such requirements will be treated as violations by PSE&G and gas service will not be furnished until they are corrected to PSE&G's satisfaction.

Use of the word “should” has the significance of a strong recommendation. Experience has shown that such recommendations represent highly desirable practices, therefore they should not be treated lightly or totally disregarded. Compliance with them is to be obtained, wherever practicable, by persuasion and explanation of the advantages to be gained. Installers are strongly urged to voluntarily comply with them, in the interest of insuring a higher degree of customer satisfaction.

2 Gas Supply and Service

2.1 Tightness of Piping System

PSE&G will not supply gas to a piping system which is not tight, or which is otherwise considered to be hazardous. A test of all new or altered piping must be observed by the proper code enforcement official. A permit must be obtained, and an inspection sticker must be present, before gas will be supplied. This test must be made before piping is concealed.

2.2 Requirements for Gas Meter Installation

The following requirements must be completed prior to PSE&G installing a gas meter at a residence with a new gas service:

- There must be an active electric service to the building where the gas meter is to be set. Refer to the Meter Set Guidelines in [Chapter 2](#) before you locate your meter and house riser.
- At least one major appliance must be installed and ready to be turned on and adjusted at the time of meter installation.
- The municipal “piping pressure test” yellow sticker must be affixed to the house piping or the premises.

2.3 Hazardous Appliances or Installation

PSE&G will not supply gas to an appliance which is not safe for operation, or is otherwise considered to be hazardous, or does not meet applicable PSE&G Standards contained in this manual and the requirements of the New Jersey Board of Public Utilities (**BPU**) and PSE&G tariff sheets filed with the BPU.

2.4 Appliance Service

PSE&G will not provide service to an appliance where access is inadequate or considered to be unsafe for the service person or where the installation does not comply with the manufacturer’s installation instructions or the *International Fuel Gas Code* or meet applicable PSE&G Standards. Federal and State Regulations and Standards of the *Occupational Safety and Health Administration (OSHA)*.

3 Disconnection of Meters

PSE&G possesses the sole right to disconnect, remove or reset gas meters, and to admit gas to any new system of piping. When installers find it necessary to disconnect a meter they shall advise PSE&G, and a service person will be dispatched to turn on the gas. No person other than a duly authorized employee or agent of Public Service shall turn gas into any new system of piping or into any old system of piping from which the use of gas had been discontinued.

4 Installation of Additional Appliances

Installers shall advise PSE&G when additional appliances are about to be installed on an existing system, to insure a service, meter and riser of adequate capacity. Upon notice, PSE&G will inspect the appliance(s) for conformance with existing codes and standards.

5 Heating and Air Conditioning Appliances

5.1 Availability of Gas Service

The availability of gas service for each proposed installation of heating, air conditioning and other gas utilization equipment shall be determined by consulting your PSE&G Local Marketing Services District Office (see [Chapter 9](#)). This should be done before specifying or purchasing heating, air conditioning and other gas utilization equipment.

5.2 Inspection

Each installation will be inspected by a representative of PSE&G to determine whether or not the equipment is approved and its installation meets these and other applicable standards. The Manufacturer's Installation Instructions shall be available during the inspection. It is recommended that PSE&G be given reasonable advance notice of the foregoing.

5.3 Violations

If any violations are observed they will be brought to the customer's attention. A reasonable time will be allowed to correct violations.

Where due to the nature of the building construction, or other reasons, it is impossible or impractical to fully comply with a specific standard, PSE&G should be consulted before the work is started for the purpose of reaching agreement as to an acceptable substitute procedure.

5.4 Installer Responsibility

On each installation it shall be the responsibility of the installer to see that the gas utilization equipment is equipped with orifice spuds of the proper size to provide the correct BTU input. On heating and air conditioning installations the installer shall be responsible for balancing the system so that all rooms can be evenly heated or cooled. The dealer or installer shall repair or replace controls, parts and wiring found to be defective until the unit has been accepted by PSE&G and placed in continuous operation. Chimney size and venting system construction must meet the manufacturer's installation instructions.

6 Services

Gas Supply Piping from Street to Building, Relations with Owners and Builders.

6.1 Application for Service

Owners are requested to make application to PSE&G Construction Inquiry Center (see [Chapter 9](#)) for service when construction of a building begins. Charges may be incurred by the Applicant as indicated in the Gas Tariff of the Public Electric and Gas Company.

6.2 Location of Service

The following provides information regarding the location of service:

1. The location of the gas service depends upon existing facilities in the street and other practical considerations. In order that installers can proceed without any delay with the interior gas piping, or other work dependent upon the location of the gas service, PSE&G will designate the point where the service will be located.
2. Gas services will not be laid in water or sewer ditches.
3. Any change requested by the customer in the location of the existing service pipe, if approved by PSE&G, will be made at the expense of the customer.

6.3 Service Entrance

Where the service will enter the building through a poured concrete wall, a sleeve for the gas service should be installed by the builder during construction. PSE&G will designate the size and location of the sleeve.

7 Meter Outlet Pressure

7.1 Normal Meter Outlet Pressure

The normal outlet pressure from the PSE&G gas meter is 6 in. Water Column (**WC**) from those services supplied by an elevated pressure system where a pressure regulator is installed ahead of the gas meter. The meter outlet pressure from a standard utilization (low) pressure system varies between 4 and 7 in. WC.

7.2 Higher Than Normal Meter Outlet Pressure (HTNP)

If HTNP is requested, PSE&G will normally supply gas pressures of 1 psig or more in increments of 1 psig for commercial and industrial customers, and 1 psig (maximum) will be supplied for residential customers. The *International Fuel Gas Code (IFGC)* requires the installation of a line pressure regulator where the appliance(s) is designed to operate at a lower pressure than the supplied pressure (IFGC Section 410). Customers seeking 1 psig delivered at the meter outlet will be required to install a Medium Pressure (**MP**) regulator with inlet ratings described below. Customers seeking greater than 1 psig delivered at the meter outlet (excluding line pressure metering) will be required to install a line pressure regulator meeting specifications determined by PSE&G.

MP Regulator Installations for HTNP Applications (1 psig at meter outlet)

The customer's lock-up MP regulator may be approved under the following conditions:

1. Standard piping
 - The regulator must have a manufacturer's inlet rating of 5 psig or better.
 - The regulator must comply with IFGC Section 410.
2. Corrugated Stainless Steel Tubing (**CSST**)
 - The regulator must have a manufacturer's inlet rating of 3 psig or better.
 - The regulator must comply with IFGC Section 410.

PSE&G **does not** consider an "Emergency" or "Exposure" rating as a substitute for the manufacturer inlet rating.

MP Regulator Installations for HTNP Applications (Greater than 1 psig at meter outlet)

The customer's lock-up MP regulator, greater than 1 psig at the meter outlet, may be approved under the following conditions:

- The PSE&G approved regulator must meet or exceed IFGC Section 410 standards.
- Customer must submit supporting design documentation through Customer Inquiry for consideration. PSE&G will supply HTNP pressure to a customer provided:
 - a. The customer's equipment requires elevated pressure.
 - b. The customer's equipment pressure ratings are compatible with the HTNP pressure or provisions are made to bring the piping pressure to within the equipment pressure ratings by approved means.
 - c. The PSE&G system at the location is capable of supplying the elevated pressure.

Note HTNP is not available from a utilization (low) pressure system.



- d. All requests for HTNP pressure should be made by the customer in writing as soon as possible through the **Construction Inquiry Center** (see [Chapter 9](#)).
- e. For requests for HTNP pressures above 1 psig, the following considerations will also apply in determining approval:
 - i. Since the minimum design pressure in the PSE&G elevated pressure system varies between 2 and 5 psig and other restrictions occur in its maintenance operations, it is PSE&G's policy whenever practicable to deliver the minimum meter outlet pressure to meet the requirements of the customer's gas utilization equipment. The customer shall obtain written approval from PSE&G of the requested higher than normal meter outlet pressure before ordering any gas utilization equipment or piping of a reduced size.
 - ii. The customer must submit the following to Construction Inquiry:
 - A detailed piping schematic showing conformance to the IFGC.
 - Equipment specifications showing the need for pressure greater than 1 psig.
 - Detail surrounding cut regulation, if applicable.
 - iii. Under certain conditions where the customer's gas load requirements and the gas utilization equipment qualifies, PSE&G will discuss with the customer the availability of supplying line pressure metering where there is no pressure regulator ahead of the gas meter. The meter outlet pressure will be approximately the same pressure as in the PSE&G elevated pressure system which will vary depending on system demand and PSE&G's operating criteria.

7.3 Pressure Testing Requirements

Customer piping requires special pressure testing before introducing HTNP gas service as follows:

1. Residential CSST receiving 1 psi shall be tested to 3 psi.
2. All other piping receiving regulated HTNP shall be tested to 15 psi. In accordance with IFGC Section 406.3.3, where the piping system is connected to appliances or equipment designed for operating pressures of less than the test pressure, such appliances or equipment shall be isolated from the piping system by disconnecting them and capping the outlet(s).
3. All piping receiving line pressure shall be tested to 1.5 times the system design pressure of the gas distribution system. Pressure tests shall be observed and certified by the local code enforcement official.

This Page Intentionally Blank

Chapter 2 – Gas Piping Installation

1 Piping Plan

It is recommended that before proceeding with the design and installation of a gas piping system, reference be made to the *International Fuel Gas Code (IFGC)*, Section 404.

When an additional appliance is to be served through any present gas piping, capacity of the existing piping shall be checked for adequacy, and replaced with larger piping by the customer if necessary.

2 Piping Requirements

This section is intended to be an informational guide. Under NJ State law, interior house piping is the responsibility of the local building code official.

This section covers basic requirements for sizing house piping for gas appliances or equipment designed to operate at normal utilization pressure. The two primary house piping pressure systems are utilization pressure and 1 psig. Utilization pressure systems are typically constructed with black iron pipe. 1 psig systems are typically constructed using Corrugated Stainless Steel Tubing (**CSST**). Due to differences in acceptable levels of hydrogen sulfide in the gas supply listed in the *International Fuel Gas Code, Section 403.4.3* and FERC gas supply tariffs limits, semi-rigid copper tubing is not recommended for use as house piping.

The PSE&G gas system contains a higher level of hydrogen sulfide than the acceptable threshold level from the International Fuel Gas Code requirements. This level is considered to be corrosive to copper and copper alloy pipe. The *International Fuel Gas Code 403.4.3* states that “copper and copper alloy pipe shall not be used if the gas contains more than an average of 0.3 grains of hydrogen sulfide per 100 standard cubic feet of gas (0.7 milligrams per 100 liters),” which is the case in the PSE&G gas system. “Threaded copper, copper alloy and aluminum-alloy pipe shall not be used with gases corrosive to such materials.”

3 Provisions for Meter Location

Meters should not be installed under decks or porches if possible. If meters are installed under first floor decks or porches, they should be installed along the edge where they can easily be read and maintained. If the deck or porch is at a different level, a meter can be installed under the deck if a clear height of 5 ft or more is available and no hazard would result from a gas leak igniting.

Meters cannot be installed under combustible stairs if they are the primary exit from the building. If the stairs are not the primary exit and no other meter location is available, a meter may be installed.

Meters shall be located at least 3 ft from electric meters and other sources of ignition such as unguarded flames, the possibility of electric sparks, furnaces, or water heaters. They shall not be placed closer than 2 ft from the front of an electric panel board on an adjacent, opposite or other wall.

Meters shall be installed with a minimum of 1 inch clearance on all sides of the meter casing. Meters shall not be installed in locations where the meter casing is in direct contact with soil or concrete walls. Alkali in concrete as well as other corrosive elements in soil can cause premature corrosion of the meter casing.

Meters shall be installed upright, level and adequately supported.

3.1 Location – Outdoors

New meter sets are normally installed as an outdoor meter set, where possible. The location of the meter set should be located near a front corner of the building whenever possible to ensure that they are readily accessible. The safety of the building and meter set piping should be a consideration when meter set location is determined.

Outdoor meter sets with pressure regulators are designed for the safe relief of excess gas pressure under emergency conditions. Pressure is relieved at the meter set to protect the downstream piping from over-pressurization.

Regulator vents must be positioned so that venting gas will not enter a building and create a hazardous condition. Determination of all vent lines must include a peck vent cap, which faces downward. Outside meter set installations require sufficient clearance from sources of ignition to ensure the safety of employees and the public.

3.2 Prohibited Outside Meter Set Locations – New Installations

Outside meter sets shall not be installed in any of the following locations:

- Meters shall not be located in walkways, driveways, or material loading or storage areas, where they are not reasonably protected and may be subject to damage.
- Meter sets shall not be installed under an opening into a building (operating windows, doors, or air intake vent).
- A regulator vent terminus shall not be installed within 2 ft of an opening into a building (operating windows, doors, or air intake vents) or air conditioning equipment.
- Meters shall not be installed under combustible stairways.
- Meters shall not be installed under decks or porches. If a deck or porch is elevated, a meter can be installed under the deck if a height clearance of 5 ft or more is available, and no sources of ignition are present.
- Meters shall be located at least 3 ft from electrical meters and other sources of ignition. Meters shall not be installed closer than 2 ft from the front of an electric panel on an adjacent wall, opposite or another wall.
- A regulator vent terminus shall not be installed within 2 ft of an opening into a building (operating windows, doors, or air intake vents) or through-the-wall air conditioning equipment.

[Figure 2.1](#) through [Figure 2.3](#) provide further guidance and clarification for the installation and clearances of outside meter sets:

Figure 2.1: Regulator Vent Terminus Clearances from Building Openings

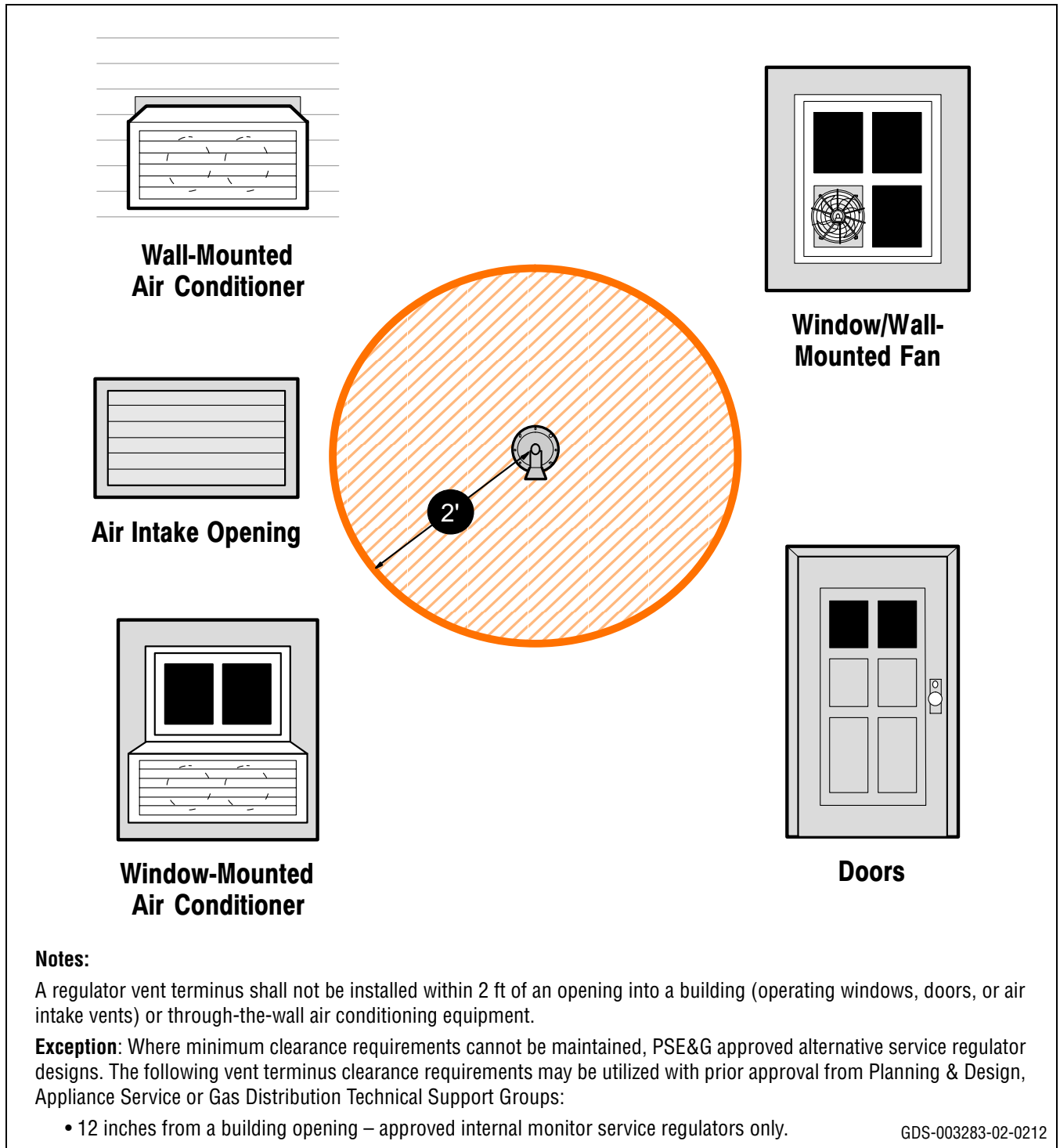
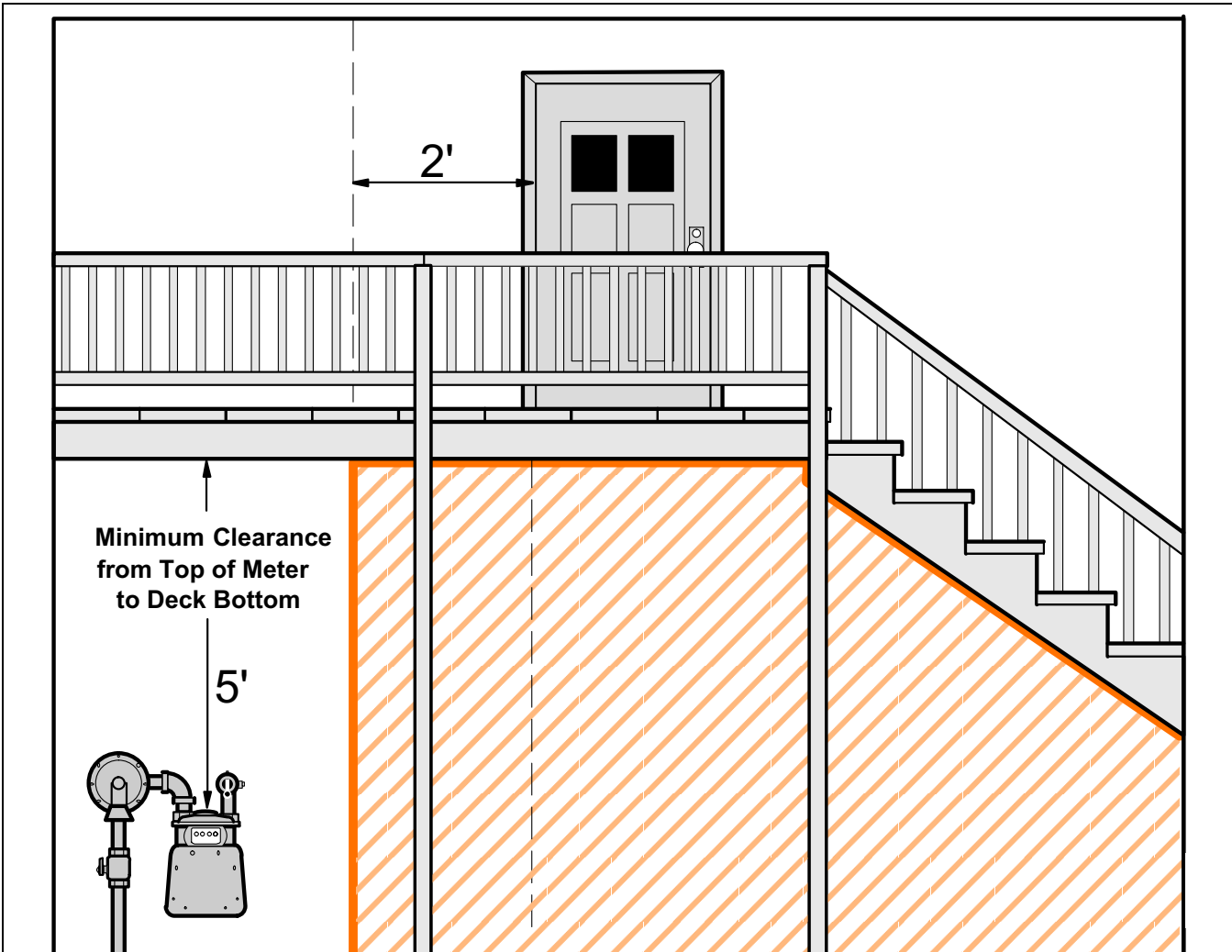

Figure 2.2: Outside Meter Set Clearances Under an Elevated Deck



GDS-003284-03-0810

Notes:

Meters shall not be installed under decks or porches. If a deck or porch is elevated, a meter can be installed under the deck if a height clearance of 5 ft or more is available, and no sources of ignition are present.

Figure 2.3: Outside Meter Set Clearance from Electric Meters or Disconnects

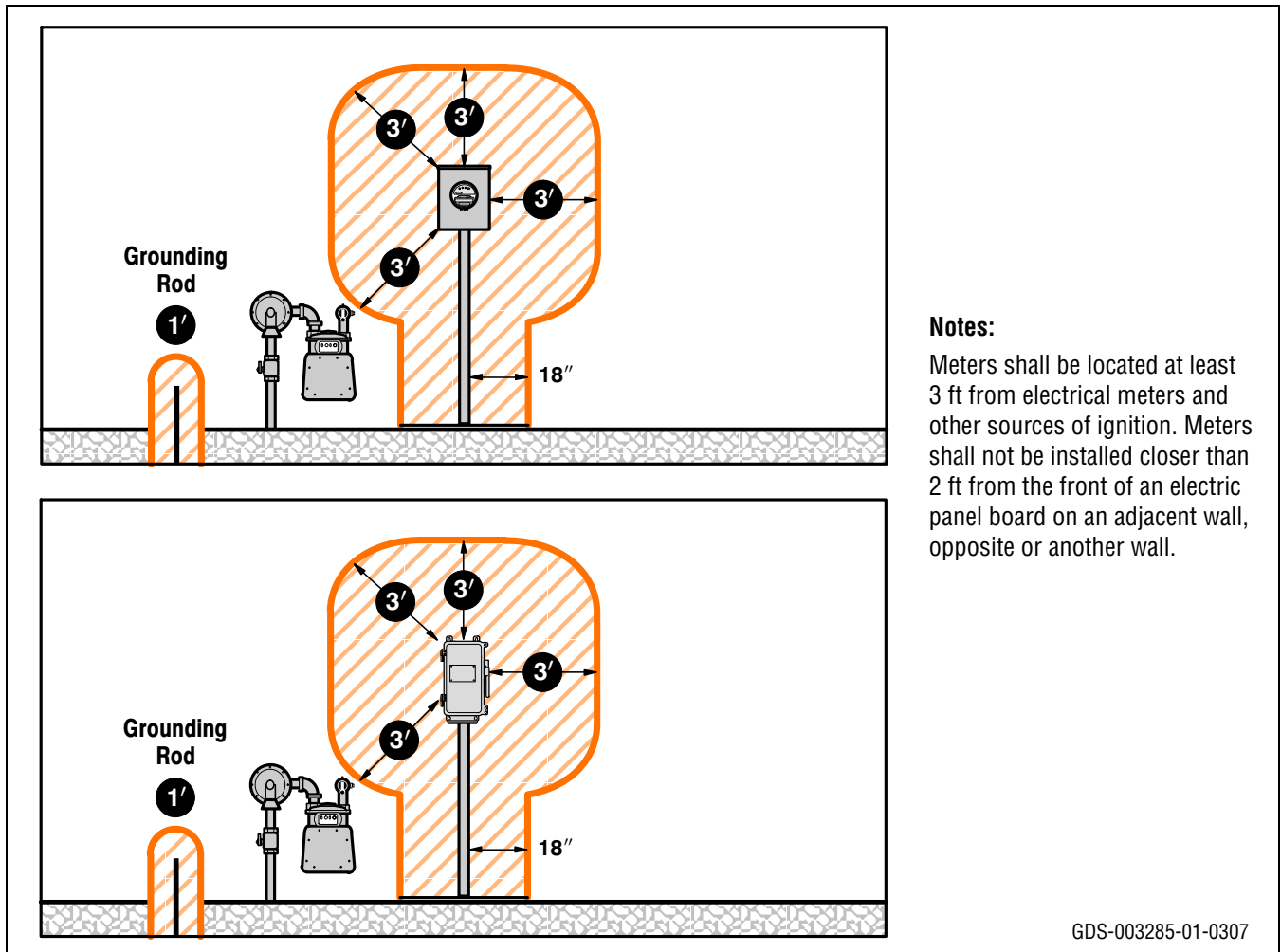

3.3 Prohibited Outside Meter Set Locations – Existing

Meter set installations found to be out of compliance with current requirements for new meter set locations may be corrected by relocating the regulator vent outlet. Prohibited vent outlet locations are as follows:

- Under an opening into a building (operating windows, doors, or air intake vent).
- Under combustible stairways.
- Under decks or porches, unless a vertical clearance of 5 ft or more is available and no sources of ignition are present.
- Less than 3 ft from electrical meters and other sources of ignition.

Caution Ensure that vent extension piping is a minimum of 1 in. diameter and does not exceed 10 ft in length (including two elbows and the required vent cap).



Vent piping extensions are required to be properly supported to handle inadvertent loading and to prevent any stress on the regulator diaphragm casing.

Regulator and Vent Piping Installation Requirements:

- PSE&G indoor service regulators are vented to the outdoors in accordance with PHMSA 49 CFR Part 192 requirements.
- PSE&G service regulators are specified to have an incorporated interval relief valve for overpressure protection of downstream piping.
- Defined clearance for external vent piping termination to prevent gas entry into buildings.
- PSE&G identified alternative service regulator designs for new and replacement meter set installations where vent piping termination clearance issues exist.
- Improved designs incorporate additional safety features, providing redundant overpressure protection mechanisms.

Internal Monitor Regulators:

- “Internal Monitor” Design incorporates a standby secondary control device (monitor) which takes over flow control in the event of a primary control failure or blockage.
- The standby monitor limits downstream pressure to approximately 12 in. wc above the regulator set point.
- The internal relief valve provides additional overpressure protection.
- Due to minimal gas flow released during an overpressure condition, PSE&G will accept a regulator vent terminus minimum distance of 12 in. for “Internal Monitor” design service regulators.
- Approved Itron Model B31-IMR and Fisher Model CS-205IR regulators are both equipped with an “Internal Monitor” design.

Outside Vent Terminus Tag:

An IMR regulator vent terminus tag (95-0588) shall be attached to all Internal Monitor Regulator installation in order to allow for quick identification of IMR regulators. For outside meter set installations, this tag shall be affixed to the regulator itself. For inside meter set installations, this tag shall be attached to the outside vent cap terminus.

Figure 2.4: IM Tag 95-0588



3.4 Meter Set Protection

Meter sets shall not be located where they are not reasonably protected and may be subject to damage. The customer is responsible to provide an appropriate location for the installation of the meter.

Customer shall furnish and maintain a suitable space for the meter and associated equipment. Such space shall be as near as practicable to the point of entrance of the gas service pipe, adequately ventilated, dry (inside installation only) and free from corrosive vapors, not subject to extreme temperatures, readily accessible to duly authorized employees or agents of Public Service and shall otherwise conform to the standards of the fuel gas subcode of the “Uniform Construction Code” and to the “General Criteria for Installation of Gas Appliances and Gas Piping,” issued by Public Service and available on request. Customer

shall not tamper with or remove meters or other equipment, nor permit access thereto except by duly authorized employees or agents of Public Service. In case of loss or damage to the property of Public Service from the act or negligence of the customer or his agents or servants, or of failure to return equipment supplied by Public Service, customer shall pay to Public Service the amount of such loss or damage to the property. All equipment furnished at the expense of Public Service shall remain its property and may be replaced whenever deemed necessary and may be removed by it at any reasonable time after the discontinuance of service. In the case of defective service, the customer shall not interfere or tamper with the apparatus belonging to Public Service but shall immediately notify Public Service to have the defects remedied.

Whenever maintenance or repair activities are performed on any existing outside meter set, the location of the outside meter set should be evaluated to ensure it is not in a hazardous location.

If the meter set piping is located within 3 ft of, and adjacent to, any garage opening, driveway, or designated parking area, and is not separated by a building wall, it may potentially be subject to vehicle impact. Meter sets require a minimum of 3 ft clearance from this “vehicle zone.”

A “vehicle zone” is defined as a street, parking space, driveway, loading dock, garage entrance, or other area intended for vehicle traffic or where vehicle traffic occurs, or is likely to occur.

1. Outside meter sets shall be installed a minimum of 3 ft from the edge of a driveway or vehicle zone. (See [Figure 2.5: Outside Meter Set Clearances from Driveway or Parking Area](#)).
2. Action shall be taken to provide protection for the meter and meter set piping.

3.4.1 Meter Set Protection Guidelines

The following guidance is offered for protecting an outside meter set from vehicle impact:

1. Barriers shall be installed to meet the requirements of Section 312 of the *International Fire Code* to protect the meter and meter set piping.
2. Installation of Excess Flow Limiter
An Excess Flow-limiting Device (**EFV**) may be installed on single residential services in the 15 psig and 60 psig design systems.
3. Outside Relocation
The existing meter set may be relocated to an acceptable alternative outside location.
4. Inside Relocation
The existing meter set may be relocated to an acceptable inside location, with appropriate design modifications for venting of regulators etc. A building wall must be between the meter set and a space that a vehicle can be operated.
5. Installation of Warning Devices
Warning devices may be installed in the immediate vicinity of the meter set. Warning devices are to be installed for the sole purpose of alerting passersby (pedestrian or vehicular) of their close proximity to a gas meter set installation.
6. Special requirements for large meter installations:
At the discretion of PSE&G and local jurisdiction, the customer may be required to provide a concrete pad for support. Concrete pads are often required to support the meter so as to minimize anticipated stresses upon the meter and connecting piping. Dimensions of the required pad will depend on various factors, such as weight and size of the meter and associated piping.

Figure 2.5: Outside Meter Set Clearances from Driveway or Parking Area

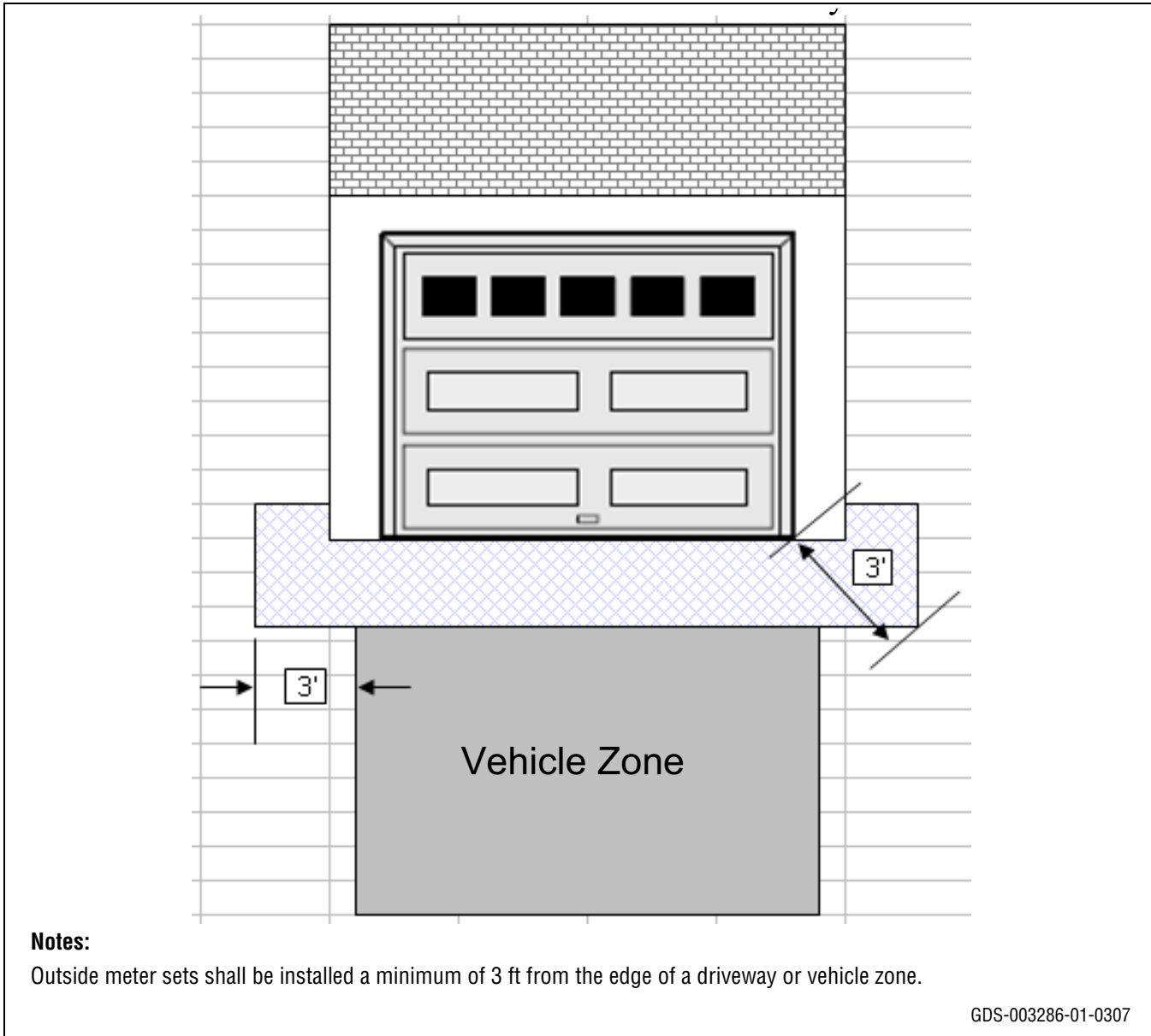

If an industrial or commercial customer requires a meter set to be installed in an area subjected to traffic conditions, the customer shall provide suitable protection (i.e., concrete bollards) to prevent meter set damage.

The following materials are approved for the construction of meter set warning devices:

Steel Post – Bollard

- Size - a minimum of 4.5 in. outside diameter, 0.237 in. wall thickness
- Length - 75 in.

Concrete

- Concrete to be 3,000 psig at 28 days

Coatings

- Steel post to be cleaned, primed, and painted high-visibility yellow

Warning devices shall be installed with a minimum of 36 in. clearance from the gas meter set piping, in accordance with the following guidelines:

- Excavate to a depth of 36 in. below grade to facilitate a minimum of 15 in. diameter round, or 15 in. by 15 in. square form, for a concrete post footing.
- Pour concrete to a depth of 15 in. in the footing and complete fill the steel post with a raised concrete crown at the top of the post.
- Backfill (compacted) to grade after allowing for sufficient curing of the concrete.
- In locations where multiple warning devices are required, install and space them not more than 4 ft apart (measured center to center on posts).

Figure 2.6: Installation of Meter Set Warning Device (Bollard)

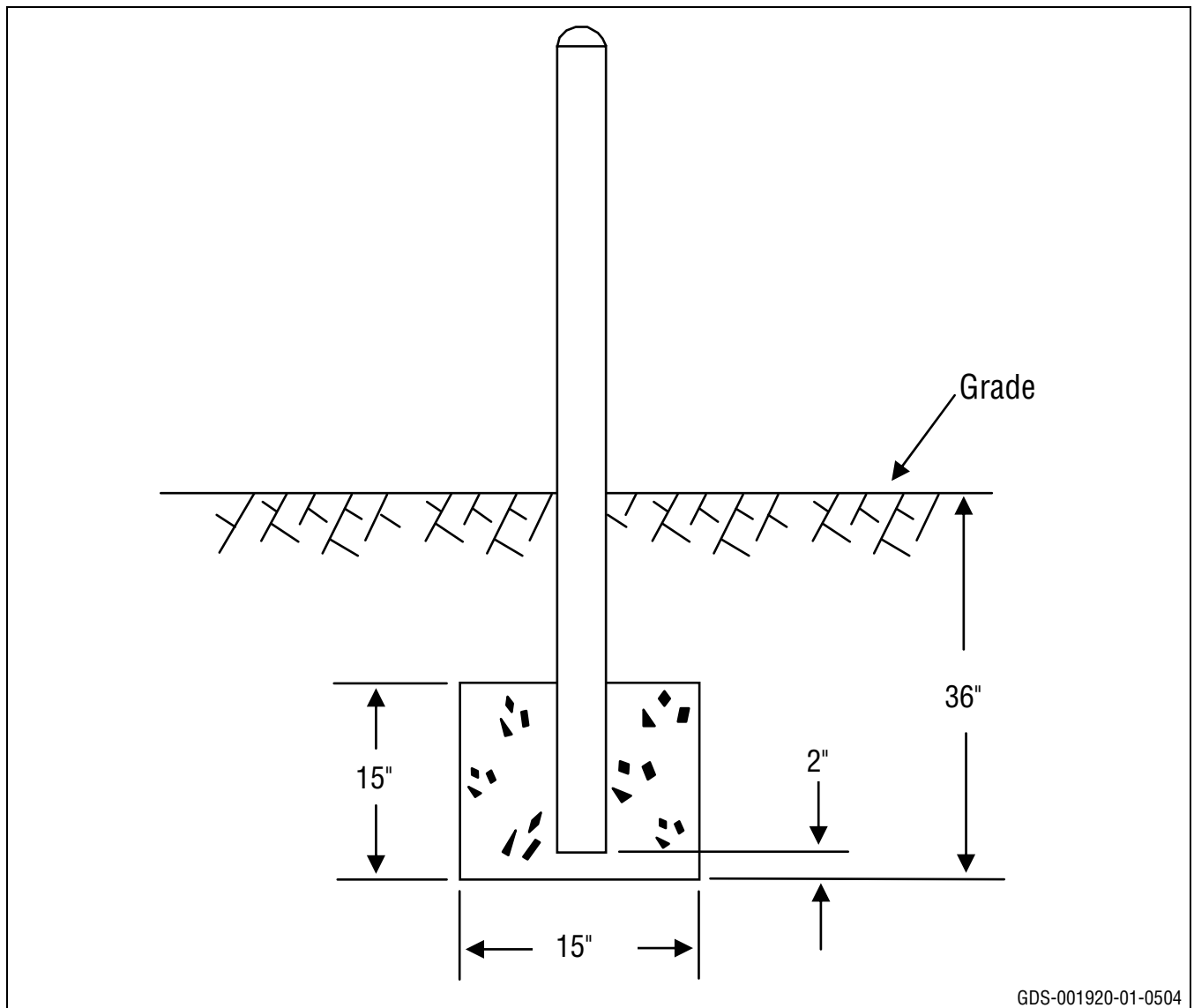

3.5 Location – Indoors

- Meter and meter set piping installed within a building must be located in a ventilated space readily accessible for examination, reading, replacement, or necessary maintenance.
- Meters installed within a building must be installed not less than 3 ft from any source of ignition, or any source of heat, which may damage the meter.
- Residential meters shall be located as close as possible to the service entrance, preferably on the front wall, and in a lighted area.
- Meters should normally be installed so that the index is 5 ft above the floor. The customer, for all installations higher than 7 ft, must provide provisions for reading, replacement, or necessary maintenance. Where possible, these provisions should be permanent.
- Meters shall be located at least 3 ft from electrical meters and other sources of ignition. Meters shall not be installed closer than 2 ft from the front of an electric panel on an adjacent wall, opposite or another wall.

3.6 Marking at Multiple Meter Installations

Gas piping at multiple meter installations shall be plainly marked by a metal tag or other permanent means attached by the installer, designating the building, part of the building, apartment, or special equipment being supplied by such piping from each meter.

4 Interconnections

4.1 Interconnections Supplying Separate Customers

When two or more meters are installed on the same premises and supply separate customers, the gas piping systems shall not be interconnected on the outlet side of the meters.

4.2 Interconnections for Stand-By Fuels

When an alternate fuel gas supply for stand-by use is connected downstream from a meter, a check valve shall be installed between the meter and the stand-by fuel piping connection. The stand-by fuel piping and the natural gas piping downstream from the check valve shall be equipped with positive shutoff valves. Both shutoff valves must be operated so at least one is shutoff at any time. Three way valves of the type that completely closes one side before starting to open the other side may be used in place of the check valve and shutoff valves specified above providing no bypass piping is installed. However, a check valve is always recommended.

5 Size of Piping to Gas Appliances

5.1 Size of Supply Piping for Gas Appliances

Gas piping should be sized in accordance with the *International Fuel Gas Code*, Section 402.

5.2 Allowable Pressure Drop

The allowable pressure loss in house piping under maximum probable flow conditions, from the meter outlet to the inlet of the gas appliance, shall not exceed 0.30 inches wc where the standard utilization pressure

service varies from 4 to 7 inches wc or refer to the *International Fuel Gas Code*, Section 402. Allowable Pressure Drop. When elevated pressure is supplied, a higher pressure drop may be acceptable (see the *International Fuel Gas Code* book, gas piping installation sizing tables (Section 402) or Sizing and Capacities of Gas Piping (Section 7.3 of this Chapter.)

5.3 Diversity Factor

In multiple tenant buildings where several appliances are supplied from a common gas pipe, a diversity factor should be used to determine the maximum gas consumption to be provided for.

In high-rise buildings the gain in gas pressure due to elevation will permit a greater than normal pressure loss in the vertical gas pipe.

Upon request, PSE&G will furnish information concerning the design of a gas piping system where diversity and elevation are involved.

5.4 Additions to Existing Gas Piping

Additions to existing gas piping shall conform to the capacity table(s) in the *International Fuel Gas Code*. Existing gas piping that does not conform to these provisions shall be replaced by the proper size of pipe. Additions shall not be made to existing pipe or tubing which is smaller than that permitted by the applicable capacity tables Section 402.3 in the *International Fuel Gas Code*.

6 Underground Gas Piping

6.1 General

Buried (underground) gas piping installed on the customer side of the gas meter shall comply with the following provisions and with the *International Fuel Gas Code*, the *Minimum Federal Safety Standards for Gas Lines* (Title 49 CFR, Part 192), and all other applicable codes and standards.

The installation, protection, testing and maintenance of customer-owned piping, whether above or underground, are the responsibility of the Customer; PSE&G assumes no responsibility in these regards. Customers may perform these tasks themselves or have them performed by plumbing/heating contractors.

Specifically, buried gas piping shall be:

- Periodically inspected/tested to be free of corrosion and leaks.
- Protected by cathodic means (in cases where the underground piping is made of steel) as outlined in this section, to include periodic inspection and replacement of the anode(s).
- Repaired if any unsafe condition is discovered.

Buried gas piping shall be located by hand whenever it is necessary to perform excavations in the vicinity of underground gas piping. Plumbers and heating contractors can assist in locating, inspecting and repairing customer piping.

Questions regarding compliance with customer-owned piping regulations may be directed to PSE&G Customer Solutions at (800) 436-7743.

6.2 Use of Plastic Piping

Plastic piping, as specified, joined, and installed according to [Section 7 – Underground Plastic Piping Installations](#), is the recommended material for customer-owned underground gas piping systems. Plastic piping installations shall comply with other applicable provisions of [Section 6 – Underground Gas Piping](#).

6.3 Material Specifications

Piping materials approved by PSE&G shall meet the following specifications:

1. Plastic Pipe
ASTM D 2513 (PE4710). See [Section 7.1](#).
2. Coated Steel Pipe
API 5L Grade A25 or ASTM A53 Grade B.

6.4 Approved Pipe Joining Methods

The following details the approved pipe joining methods:

1. Plastic – (See [Section 7.7](#))
2. Steel

Steel piping up to and including 1-1/4 inches shall be of the threaded construction with line pipe couplings. Steel pipe larger than 1-1/4 inches may be made of threaded, welded or compression coupled construction. Joints within 20 ft. of the building shall be either lock type compression coupling, welded, Posi-Hold couplings or regular compression couplings with retaining straps.

6.5 Underground Corrosion Control

The following provides information regarding underground corrosion control:

1. All steel pipe and fittings which are buried shall be installed, coated and cathodically protected.
2. An approved insulated shut-off shall be installed on all metallic fuel lines at the outlet side of the gas meter. An insulator shall also be installed at the terminus of the line itself.
3. Magnesium anodes are to be installed on all buried steel fuel line piping in accordance with the recommendation of qualified Gas Company personnel to prevent underground corrosion on the line. They are to be attached to the steel fuel line by thermite welding, by using an approved ground clamp or by brazing the copper anode wire to the pipe. The anode(s) shall then be buried a minimum of 3 ft. below the fuel line piping. Anode connection points are required to be coated for cathodic protection.
4. Electrical grounding of fuel lines is prohibited.
5. Where a section of steel fuel line is exposed, the pipe shall be painted or coated in accordance with approved PSE&G field coating systems.

6.6 Notification and Permits

All permits (governmental or otherwise) shall be obtained by the Owner or their Contractor. The Owner or their Contractor shall also be responsible for notifying other utilities of pending work and request mark-outs of facilities using the One-Number-To-Call System (800) 272-1000 or by calling 811.

6.7 Pressure Test

All piping and associated equipment shall be pressure tested to the satisfaction of local code enforcement after construction and before placing in service. PSE&G will apply a “Static Meter Test” when the gas meter is installed. Any leak detected shall be located and repaired by the Owner or Contractor before any new section of piping is to be placed permanently in service.

If plastic pipe is used, care shall be taken to keep air pressure from exceeding the design rating of the pipe.

7 Underground Plastic Piping Installations

7.1 Plastic Piping Materials

Plastic pipe, tubing, and fittings used underground shall conform with the Standard Specification for Thermoplastic Gas Pressure Pipe, Tubing and Fittings, ASTM D2513. Pipe to be used shall be marked “GAS” and “ASTM D2513”. Plastic pipe or tubing shall not be used for gas piping inside or beneath buildings, or outside, for above ground applications. Plastic pipe or tubing shall not be used for venting gas pressure regulators.

7.2 Plastic Rated Sizes

Plastic piping and tubing is available in various Standard Dimension Ratios (**SDR**). The SDR rating is needed to match fittings to the pipe chosen. The pressure rating of any one SDR remains constant regardless of the outside diameter. The allowable dimensions and pressures for PE4710 Piping and Tubing in [Table 2-1](#) and [Table 2-2](#).

Table 2-1: Specifications for High Density PE4710 Plastic Tubing

Normal Pipe Size (inches)	Outside Diameter (inches)	Inside Diameter (inches)	Wall Thickness (inches)	Maximum Allowable Working Pressure (psig)
1/2	0.625	0.445	0.090	125
1	1.125	0.945	0.090	89
1-1/4	1.375	1.195	0.090	72

Table 2-2: Specifications for High Density PE4710 Plastic Tubing

Normal Pipe Size (inches)	SDR	Outside Diameter (inches)	Inside Diameter (inches)	Wall Thickness (inches)	Maximum Allowable Working Pressure (psig)
2	11	2.375	1.943	0.216	102
3	11.5	3.500	2.886	0.307	98
4	11.5	4.500	3.710	0.395	98
6	13.5	6.625	5.643	0.491	82
8	13.5	8.625	7.270	0.639	82

7.3 Plastic Tubing and Piping Size

The gas-carrying capacities for different sizes and lengths of plastic tubing and pipe are shown in [Table 2-3](#).

Gas piping should be sized in accordance with the *International Fuel Gas Code, Section 402*.

Table 2-3: Capacity of Plastic Tubing and Pipe in Cubic Feet Per Hour

Size	Wall Thickness	ID	20 ft	30 ft	40 ft	50 ft	60 ft	70 ft	80 ft	90 ft	100 ft	125 ft	150 ft	175 ft	200 ft
Tubing															
1/2 in.	0.090 in.	0.445 in.	105	84	72	62	58	53	50	46	44	39	35	32	30
3/4 in.	0.090 in.	0.695 in.	210	169	144	128	116	107	99	93	88	78	71	65	60
1 in.	0.090 in.	0.945 in.	379	304	260	231	209	192	179	168	159	141	127	117	109
1-1/4 in.	0.090 in.	1.195 in.	656	527	451	400	362	333	310	291	275	243	221	203	189
Pipe															
2 in.	0.216 in.	1.943 in.	2090	1680	1440	1280	1160	1060	989	928	877	777	704	648	602
3 in.	0.318 in.	2.886 in.	5900	4740	4050	3590	3260	3000	2790	2610	2470	2190	1980	1820	1700
Note: For gas pressure of less than 2 psig with a pressure drop of 0.3 inches w.c. (based on a 0.60 specific gravity gas).															

7.4 Storage and Handling

Care shall be exercised to protect Polyethylene pipe and tubing from fire and excessive heat and to avoid contact with chemicals known to be harmful to PE, such as paint remover and thinners, varnish, lacquers, kerosene, fuel oils, diesel oils, gasoline, cleaners, degreaser and solvents. In temperatures above 80°F, PE tubing shall be protected from direct sun rays prior to installation. Rough handling shall be avoided. PE tubing shall not be pushed or pulled over sharp projections, dropped, or have objects dropped on it. It is desirable to store PE pipe and tubing indoors. When it must be stored outdoors the total accumulated time of outdoor storage shall not exceed one year from the date of extrusion, shown on the wall of the pipe.

7.5 Installation

The following details the method of installation:

1. Plastic pipe shall be installed outside, underground only.
2. PE pipe and tubing shall be laid on undisturbed or well compacted soil or other continuous support. Suitable rock free backfill shall always be placed around the pipe or tubing. Pneumatic tamping shall not be used for the first 12 inches above the pipe.
3. Piping shall be buried a sufficient depth or covered in a manner so as to protect the piping from physical damage. Consideration shall be given to encasing plastic pipe and tubing with a steel sleeve when future construction or heavy surface loading is anticipated such as crossovers, sewers, etc.
4. The pipe or tubing shall be free of cuts and scratches deeper than 10% of the wall thickness. Defects in pipe, tubing or fittings shall not be repaired. When such defects are located, the defective material shall be replaced.
5. PE pipe shall not be used inside buildings or above ground.

6. An electrically continuous corrosion resistant tracer wire (min. #12 AWG) shall be buried near but not touching the plastic pipe to facilitate locating. The wire shall terminate above ground at a building wall or riser so that locating instruments can be connected.

7.6 Piping Through Foundation Wall

The following details the requirements for piping through a foundation wall:

1. PE piping sizes, for which there is no commercially available service head adapter specifically manufactured for the purpose, must be terminated outside the foundation wall and connected to a metallic pipe in accordance with the section titled “Joining Plastic Pipe.”
2. Sizes of PE tubing and piping sizes for which such a fitting is available may be installed through a foundation wall within a steel sleeve. The steel sleeve shall bridge the foundation backfill region and terminate on firm undisturbed soil.
3. Inside the building, the plastic pipe or tubing must be continuously encased in the steel sleeve and terminated as close to the entrance wall as practical with a service head adapter specifically manufactured for the purpose. Both ends of the steel sleeve must be reamed to remove any burrs or sharp edges.
4. An end protector bushing (which may be purchased commercially or constructed from a 3 inch long piece of tubing identical to the carrier pipe) shall be placed in the annular space between the carrier pipe and the casing. When fabricating an end protector bushing the 3 inch piece of tubing shall be slit axially, placed around the carrier pipe and installed half way into the steel sleeve to protect the carrier pipe from bearing on the open end of the steel sleeve.

7.7 Joining the Plastic Pipe

The following details the requirements for joining plastic pipe:

1. PE pipe and tubing may be joined by fusion, or by mechanical fittings. All joints shall be constructed in accordance with procedures in the Code of Federal Regulations, 49 CFR 192.283 and 192.285, and approved by PSE&G. All fusion joints shall be inspected by a PSE&G representative prior to backfilling.
2. Transition fittings between plastic and other piping shall conform to the above requirements for mechanical fittings. Compression joints on metallic pipe connected to plastic pipe shall be constructed to prevent pull out.
3. Metallic fittings and pipe, connected to plastic pipe shall be protected from corrosion in accordance with National Association of Corrosion Engineers (**NACE**) RP 01-69. Coating primers shall not be allowed to come in contact with plastic pipe.
4. Only fusion fittings expressly manufactured for use with the PE pipe being used are permitted. It is preferred that both the fittings and the pipe be produced by the same manufacturer.
5. Mitered joints are not permitted.
6. Joints shall not be located in pipe bends.

8 Flexible Tubing Systems

8.1 General

The installation of flexible tubing systems shall be made in accordance with the manufacturer's instructions, their listing, applicable codes and the "General Guidelines For Flexible Tubing Natural Gas Systems" ([Chapter 3](#)).

9 Natural Gas Odorant – Safety Information

The purpose of this notice is to provide customers and contractors, who work on natural gas piping, appliances and equipment, with additional safety information on natural gas odorant and the potential for odor fade.

PSE&G adheres to United States Department of Transportation (**DOT**) and NJ Board of Public Utilities (**BPU**) rules and regulations regarding the odorizing of natural gas. Even though a distinctive odor is added to natural gas to assist in the detection of leaks, you should not rely solely on your sense of smell to determine if a gas leak exists or if natural gas is present. Some individuals may not be able to detect the odorant because they have a diminished sense of smell or olfactory fatigue, or because the odor is being masked by other odors in the area. In addition, certain conditions such as **odor fade** may cause odorant to diminish so that it is not readily detectable.

Odor fade (loss of odorant level) occurs when the level of odorant in the gas is reduced due to physical and/or chemical processes including adsorption, absorption and oxidation. In gas piping systems, odor fade occurs predominantly in installations of new pipe rather than in existing pipe. It is more pronounced in new steel pipe of larger diameters and longer lengths. However, it can also occur in plastic pipe and in smaller and/or shorter pipe installations. New pipeline installations or additions of new piping segments may require the conditioning of the pipe before it is placed into service to prevent occurrences of odor fade.

If a natural gas leak occurs underground, the surrounding soil may cause odor fade. Other factors that may cause odor fade include: the construction and configuration of the customer's gas facilities; the presence of rust, moisture, liquids or other substances in the pipe; and gas composition, pressure and/or flow. Intermittent, little or no gas flow over an extended period of time may also result in the loss of odorant until gas flow increases or becomes more frequent. Many appliance manufacturers include in their installation manuals information on the potential for odorant fade.



Warning Do not purge the contents of a gas line into a confined space. Purging of a gas line should only be done by a licensed, qualified professional and should be done in a well-ventilated area or by venting the contents to the outside atmosphere. Always use gas detection equipment during purging operations or when otherwise working on gas piping systems to ensure that no natural gas is present that may result in a combustible or hazardous atmosphere.

DO NOT rely on your sense of smell alone to detect the presence of natural gas.

Consult your local plumbing code, mechanical code, international fuel gas code and/or your NJ Department of Community Affairs (**NJDCA**) for more information. When installing gas appliances or equipment, the manufacturer's instructions should be followed in accordance with the local code authority (NJDCA).

For additional information on natural gas safety, please visit:
http://www.pseg.com/home/education_safety/safety/gas_safety.jsp

Chapter 3 – Guidelines for Flexible Tubing (CSST) – Natural Gas Systems

1 System Design

1.1 General Description

Where the builder/homeowner has decided to install Corrugated Stainless Steel Tubing (**CSST**), and it has been approved by the local code official, PSE&G will provide Higher Than Normal Delivery Pressure (**HTNP**) of 1 psi gas at the meter, provided that sufficient system main pressure is available (see [Chapter 1, Section 7.2](#)). Contact the local marketing office listed in [Chapter 9](#) for details.

In 1993, PSE&G approved the use of CSST for house piping. The delivery pressure design at the meter outlet was 14 inches wc. The tubing size was designed to have a pressure drop of approximately 9 inches wc which would deliver 5 inches wc to the appliances under full load conditions. This 14 inches wc delivery system was replaced in 1996 by a 1 psi delivery system and is no longer used for new installations. Gas is now delivered to the meter outlet at 1 psi which in turn supplies a secondary gas pressure regulator installed downstream. The pressure design at the secondary regular outlet is 7 inches wc.

All CSST systems shall be designed and installed by installers who have been trained and certified according to the requirements of the manufacturer and this section (which is consistent with the requirements set forth in BOCA and the *International Fuel Gas Code*). In cases where the requirements of this section are in conflict with local codes, the local codes must take precedence, unless the local authority having jurisdiction approves a variance or change. **AS technicians shall ensure all new/replacement CSST installations have been approved by local code enforcement prior to energizing that installation/section of piping.**

Since the flow characteristics of AGA approved CSST differs by manufacturers for the same nominal sizes, the manufacturer's sizing tables shall be used when sizing CSST.

In the manufacturer's tables flow designations are listed as Equivalent Hydraulic Diameter (**EHD**), a measure of the relative hydraulic efficiency of the tubing. The greater the value of the EHD, the greater the capacity of the tubing. For example, a 3/4 inch CSST with an EHD of 24 will have more capacity than a 3/4 inch CSST with an EHD of 22. The capacity tables in the *International Fuel Gas Code* use designations of EHD which can be referenced to specific manufacturers' nominal sizes by consulting the manufacturers' design and installation guide.

1.2 Tubing and Manifold System Components

There are basically two types of system design as shown in the following sketches.

- The parallel branch system has the manifold close to the meter outlet and individual house lines are installed to each appliance.
- The optimized parallel arrangement has the manifold installed at a location closer to the appliances and individual house lines are installed from the manifold to each appliance.

The decision to use either of these (or a combination of both) is normally dependent on the economics of the combinations of the lengths of each line vs. the diameters. Normally, in order to minimize the tubing lengths from the meter, a tubing junction manifold should be installed as close as possible to the major appliances.

Figure 3.1: Parallel Branch Arrangements

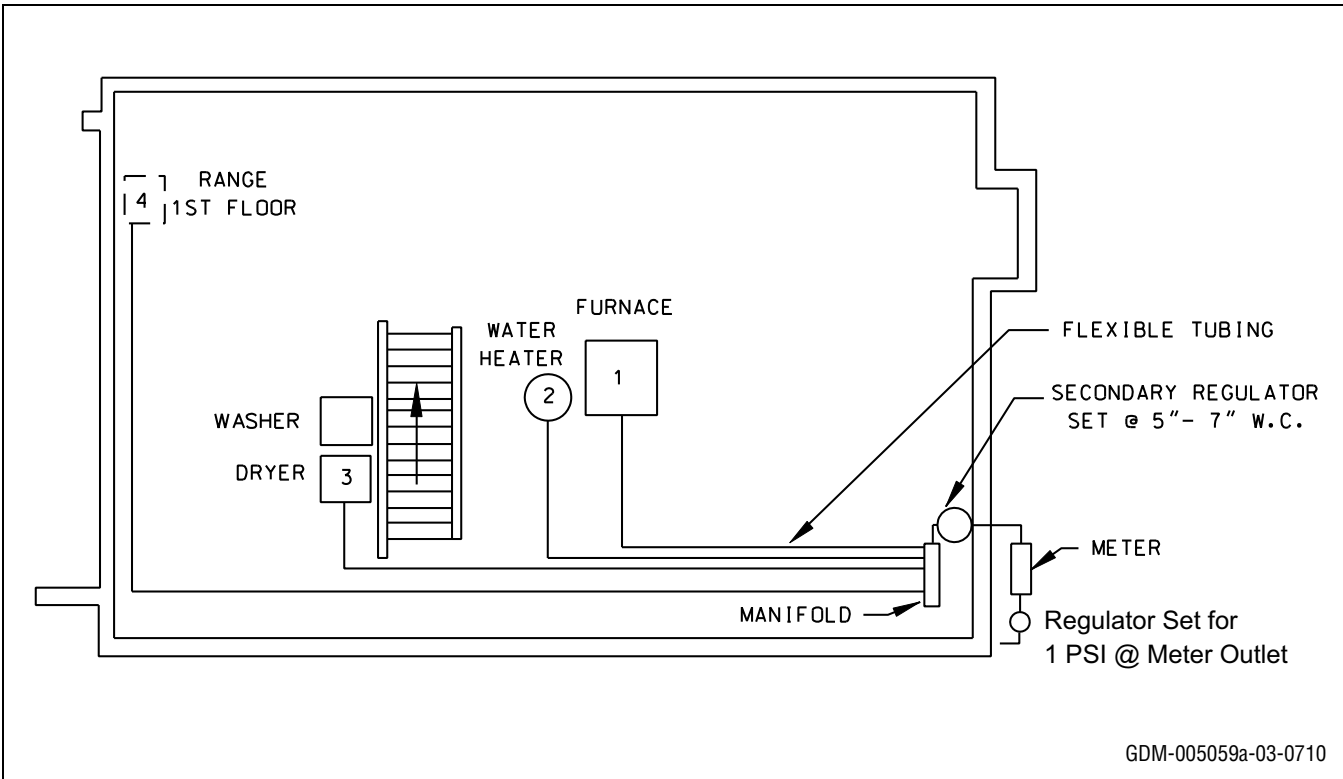
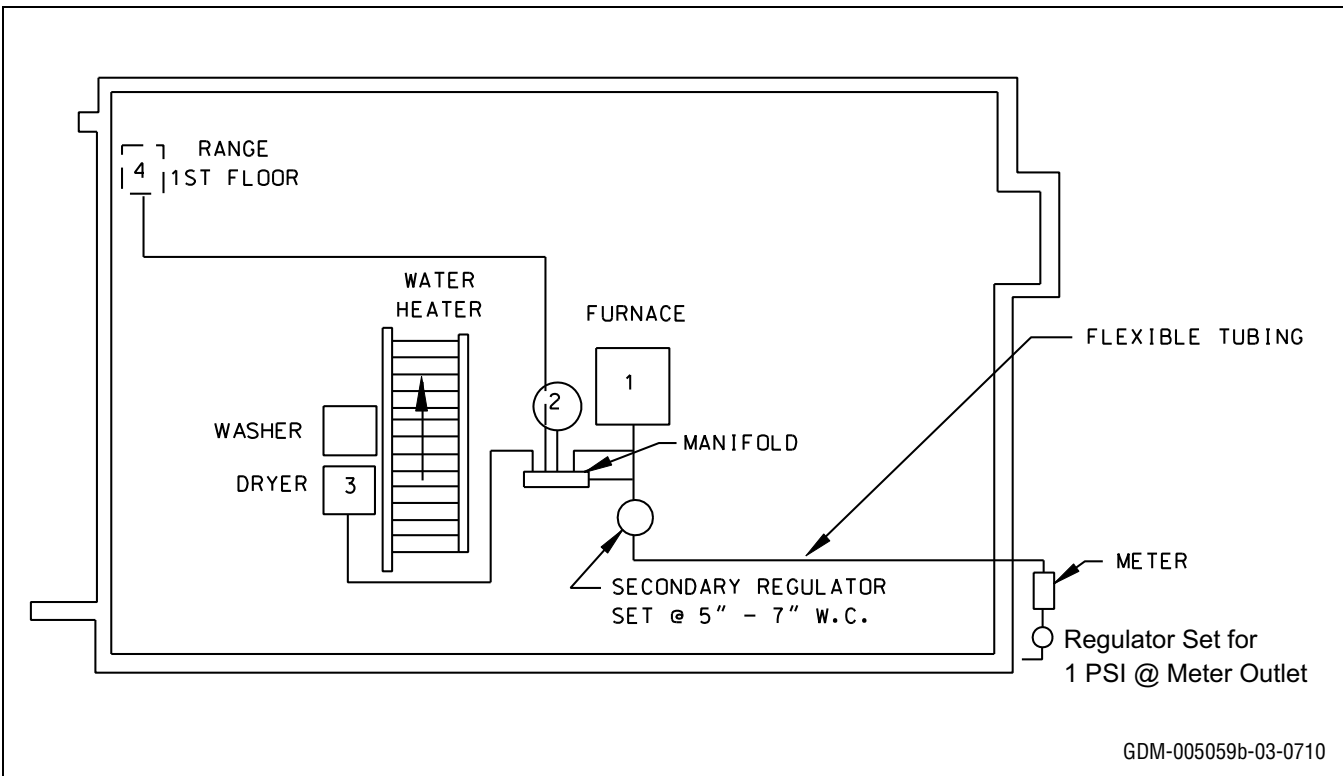

Figure 3.2: Optimized Parallel Arrangements



1. Regulator Pressure – Delivery and Failure

a. Primary Regulator

The regulator used to supply the 1 psi system shall normally be the one shown in the Gas Distribution Standards and set to deliver 1 psi at the outlet of the regulator. The sizing charts were based on the assumption of 1 psi at the outlet of meter. Where investigation shows that the tubing selected is using the maximum allowable pressure drop, the next larger size tubing should be considered. If non-standard regulators are used, the maximum failure pressure shall be kept as low as practical, but in no event exceed 3 psi in accordance with the International Fuel Gas Code, Section 406.4.1.

b. Secondary Regulator

In order to preclude the possibility of over pressuring appliance regulators, a secondary house regulator must be installed before (upstream of) any manifold or separate branch lines to appliances. This regulator shall be of sufficient capacity to accept a 1 psi inlet pressure and deliver 5 to 7 inches wc to the various branch lines. The secondary regulator shall be designed to handle 3 psig inlet pressure in the event of a primary regulator failure.

2. Tubing Manifold and System Components

An accessible, lever-handled shut-off valve of approved type should be installed at the manifold inlet and at each appliance. To minimize entire system shutdown, an optional shut-off valve is also recommended on each line at the outlet of the manifold. Only those valves that are tested per ANSI/ASME B16.44 as a manual gas valve for pressures 1 psi or greater shall be used. All gas appliances rated for inches water column pressure operation will have their own regulator, reducing house pressure to approximately 3.5 inches wc pressure. **This appliance regulator shall not be removed.**

Figure 3.3: Tubing Manifold System Components

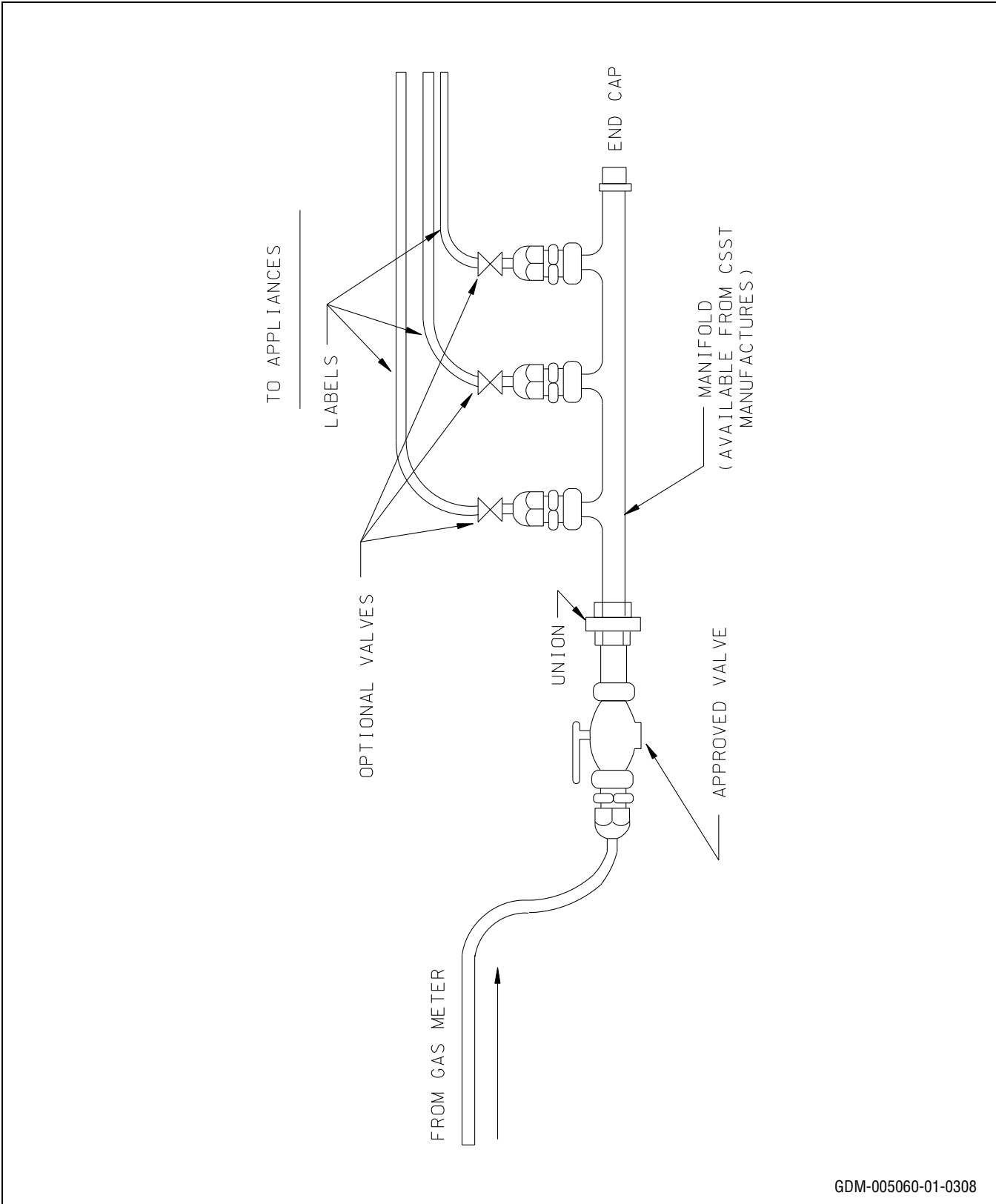

GDM-005060-01-0308

1.3 Tubing Sizing Procedure

Since the flow characteristics of each brand of AGA approved CSST tubing are different, each manufacturer publishes their own sizing tables and they shall be used accordingly.

The system must be properly sized and installed if it is to perform correctly. The tubing should be sized in 2 sections. First, from the primary regulator to the secondary regulator, and second, from the secondary regulator to the appliances.

The tubing from the primary regulator to the secondary regulator must be of sufficient size to limit pressure drop to no more than 15 inches wc under maximum flow conditions. This will allow the primary regulator to be set at 1.0 psi outlet pressure and deliver no less than approximately 12 inches wc to the secondary regulator.

Tubing from the secondary regulator to each appliance must be sized so that with the secondary regulator set to deliver 5 to 7 inches wc at the regulator outlet, sufficient gas will be delivered to allow proper operation of the appliance. The secondary regulator shall be designed to handle 3 psig inlet pressure in the event of a primary regulator failure.

To Size Section 1, Determine:

- The length of gas tubing from the meter to the tubing manifold.
- The total load of all gas appliances.

To determine the correct size of the gas line between the meter and the secondary regulator at the tubing manifold, refer to the manufacturer's recommendations.

To Size Section 2, Determine:

- The maximum demand in CFH for each appliance served by the tubing manifold.
- The length of piping between the tubing manifold and the inlet connection of the appliance.

Refer to tables supplied by the manufacturers to determine the correct size of tubing under these conditions.

1.4 Examples

1.4.1 Sizing Example #1 – Parallel Branches

Structure – Single Family Residence (House or Apartment)

Material – CSST

Reference Source – Manufacturer's sizing tables

Installation Type – Minimum Distance – Meter to Secondary Regulator

Maximum Distance – Secondary Regulator to Appliances

Note

This same sizing procedure would be utilized for CSST but the manufacturers' sizing tables would be used.



Figure 3.4: Illustration for Example #1

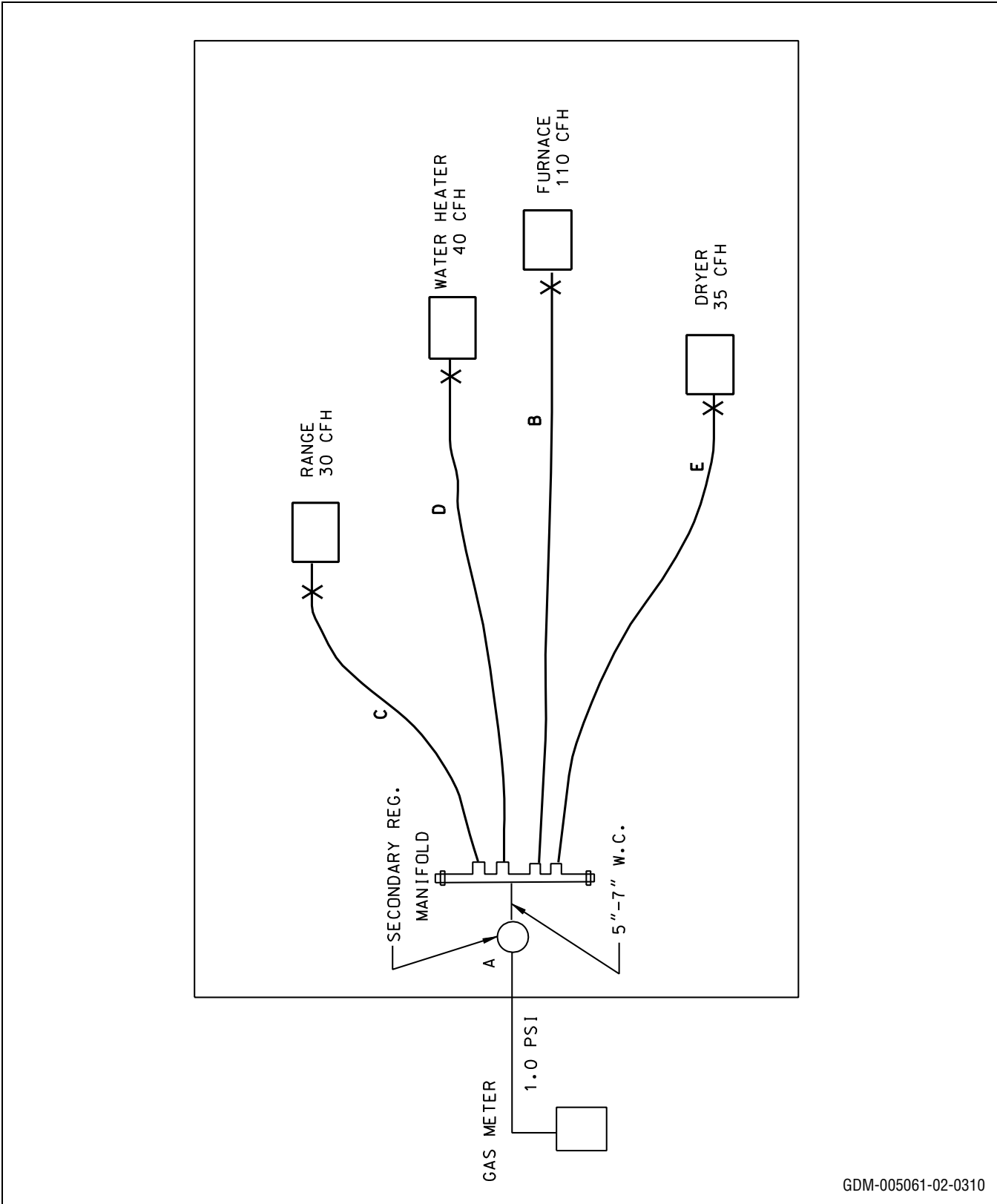

Table 3-1: Sizing Table for Example #1

Appliance	Load	Run (See Figure above)	Length
Range	30 CFH	C	30 ft
Furnace	110 CFH	B	40 ft
Water Heater	40 CFH	D	25 ft
Dryer	35 CFH	E	35 ft
Total	215 CFH	A	15 ft

Step 1 To Size Section A – Meter to the Secondary Regulator

Determine distance from the Meter to the Secondary Regulator = 15 ft

Determine total load supplied by A = 215 CFH

Consult the CSST Manufacturer’s sizing table to select the correct size CSST tubing to supply 215 CFH or greater at a distance of 15 ft.

Step 2 To Size Section B – Secondary Regulator to the House Heater

Length is 40 ft

Load is 110 CFH

Consulting the CSST Manufacturer’s sizing table to select the correct size CSST tubing to supply 110 CFH (secondary regulator to appliance) at a distance of 40 ft.

Step 3 To Size Section C – Secondary Regulator to the Range

Length is 30 ft

Load is 30 CFH

Consulting the CSST Manufacturer’s sizing table to select the correct size CSST tubing to supply 30 CFH at a distance of 30 ft.

Step 4 To Size Section D – Secondary Regulator to the Water Heater

Length is 25 ft

Load is 40 CFH

Consulting the CSST Manufacturer’s sizing table to select the correct size CSST tubing to supply 40 CFH at a distance of 25 ft.

Step 5 To Size Section E – Secondary Regulator to Dryer

Length is 35 ft

Load is 35 CFH

Consulting the CSST Manufacturer’s sizing table to select the correct size CSST tubing to supply 35 CFH at a distance of 35 ft.

1.4.2 Sizing Example #2 – Optimized Parallel

Structure – Single Family Residence (House or Apartment)

Material – CSST

Reference Source – Manufacturer’s sizing tables

Installation Type – Maximum Distance – Meter to Secondary Regulator

Minimum Distance – Secondary Regulator to appliance

Note This same sizing procedure would be utilized for CSST but the manufacturers’ sizing tables would be used.



Figure 3.5: Illustration for Example #2

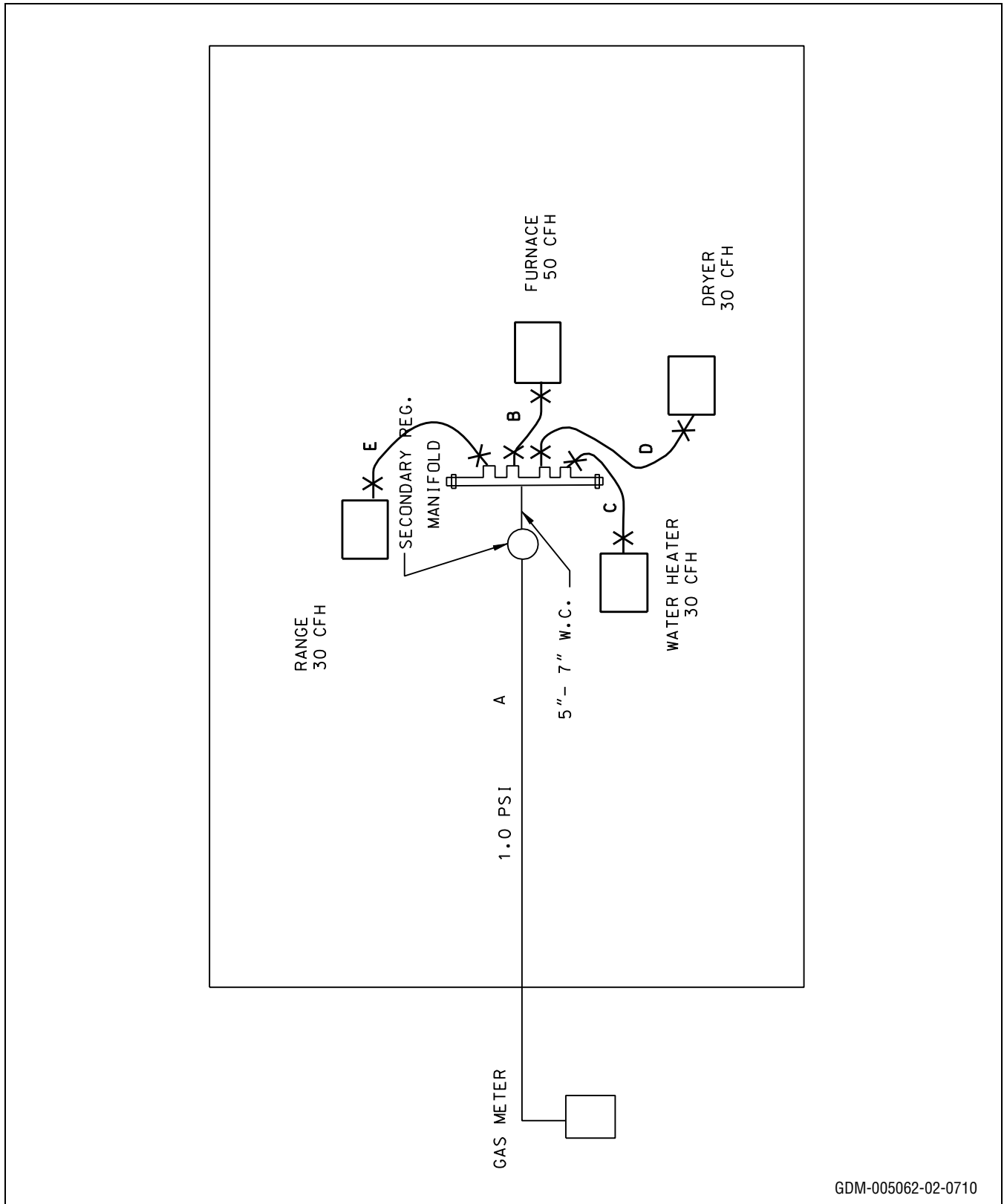

Table 3-2: Sizing Table for Example #2

Appliance	Load	Run See Figure above	Length
Range	30 CFH	E	45 ft
Furnace	50 CFH	B	10 ft
Water Heater	30 CFH	C	20 ft
Dryer	30 CFH	D	30 ft
Total	140 CFH	A	95 ft

Step 1 To Size Section A – Meter to the Secondary Regulator

Determine distance from the meter to the Secondary Regulator (95 ft).

Determine total load (140 CFH)

Consult the CSST Manufacturer’s sizing table to select the correct size CSST tubing to supply 140 CFH or greater at a distance of 95 ft.

Step 2 To size the other sections

Consider the secondary regulator to be the source rather than the meter. Size the individual parallel runs to each appliance. Do this using the distance from the secondary regulator to the appliance and load of the appliance.

Step 3 To Size Section “B” (Secondary Regulator to the Furnace)

Secondary Regulator to furnace = 10 ft

Load is 50 CFH

Consulting the CSST Manufacturer’s sizing table to select the correct size CSST tubing to supply 50 CFH at a distance of 10 ft.

Step 4 To Size Section “C” (Secondary Regulator to the Water Heater)

Secondary Regulator to water heater = 20 ft

Load is 30 CFH

Consulting the CSST Manufacturer’s sizing table to select the correct size CSST tubing to supply 30 CFH at a distance of 20 ft.

Step 5 To Size Section “D” (Secondary Regulator to the Dryer)

Regulator to dryer = 30 ft

Load is 30 CFH

Consulting the CSST Manufacturer’s sizing table to select the correct size CSST tubing to supply 30 CFH at a distance of 30 ft.

Step 6 To Size Section “E” (Secondary Regulator to the Range)

Regulator to range = 45 ft

Load = 30 CFM

Consulting the CSST Manufacturer’s sizing table to select the correct size CSST tubing to supply 30 CFH at a distance of 45 ft.

1.5 Low Pressure System

To size as an extension to existing piping system at low pressure (5 to 6 inches wc) use the CSST Manufacturer's sizing tables.

2 Installation Practices

2.1 General Guidelines

Piping installed for 1 psi pressure systems shall be AGA certified corrugated stainless steel tubing. See the manufacturer's instruction manual for CSST.

Piping runs can be located several places within the housing structure, depending on local building codes, examples of some locations include:

- Beneath floor joists
- Through floor joists
- Along side of floor joists
- Inside interior wall cavities (parallel to and through studs)
- Through conduit embedded in concrete floors or walls

Tubing run parallel to the joints must be fastened to the center of the vertical face of the joist. Tubing run on top of ceiling joists is permitted as long as the members are strong enough to sustain the weight of the tubing. Tubing run at right angles to the joists, shall be fastened to the underside of the joist, preferable close to the water pipes, conduit ductwork, or center beams. Tubing run at right angles to joists may be drilled through the center of the joists. See section on drilling for details.

The following are some general guidelines for installing the tubing.

1. All piping runs should be roughly parallel or at right angles to the joists.
2. Branch connections, if required, may be taken off the bottom, top, or side of horizontal runs with approved fittings.
3. All horizontal tubing must be supported at least every 6 ft.
4. All vertical tubing must be supported every 8 ft.
5. The ends of the tubing must be temporarily capped or taped closed prior to installation to prevent the entrance of dirt, dust or other debris.
6. Avoid contact with sharp objects or harmful substances. The tubing must be replaced if damage occurs as a result of impact, crush or other abuse.
7. While running tubing, avoid sharp bends, kinking or twisting of the tubing.
8. Undue stress or strain on the tubing and fittings is to be avoided during and after installation.

Even rough-in outlet, including a valve or tubing fitting, must be plugged or capped immediately after installation. It must remain sealed until the gas equipment is connected. The threaded side of the tubing to pipe adapter must extend at least one inch through any finished wall. This allows for pressure testing after rough installation and prevents dirt or debris from entering the system.

2.1.1 Drilling

Drilling through beams and joists is acceptable if allowed by local building codes, and should only be considered after thorough discussion with the authority having jurisdiction and the builder.

The size of the hole drilled through top plates, top frame members, and sole plates, to allow passage of the tubing, should not exceed 1/2 of the width of the member. The hole should be bored through the center of the member.

Note Do not notch a joist (either top or bottom)!



When a hole is to be bored in a joist, the hole should be located not less than 2 inches away from the floor or ceiling, and the hole diameter should not exceed 1/3 of the depth of the joist. This is done to protect the tubing from possible nail penetrations.

When holes are to be bored in vertical members of the wall framing, the size of such holes should not be larger than 1/3 the width of the member.

Wherever possible, installation clearance holes for routing tubing through studs, joist, plates, etc., should have a diameter of not less than twice the outside diameter of the tubing.

Note Fire stopping material must be used at all floor penetrations.



2.2 Identification (Labeling)

All tubing carrying 1 psi gas pressure shall be labeled to read “1 psi NATURAL GAS” at the meter outlet, and every 6 ft of exposed piping, up to the inlet of the secondary regulator. The tubing should be marked anywhere the gas tubing can be confused with other tubing in the vicinity (water lines, refrigeration lines, etc.).

These labels are available at your local Marketing Services Office (See [Chapter 9](#)).

2.3 Protection

The flexible tubing shall be protected in cases where it comes in contact with sharp building material. The flexible tubing shall also be sleeved when penetrating concrete or masonry slabs or walls. This may be accomplished with armafex or similar material where fire-rated construction is not required. When fire-rated construction is required, consult the building code for the handling of penetrations.

The flexible tubing shall be protected from puncture threats, using shielding devices or striker plates of 20 gauge minimum thickness, at all joints of tubing support or penetration through studs, joists, plates, or similar structures as shown in the Manufacturer’s installation procedures and/or as listed under “Protection Required”. The best protection however, is to install the tubing in those out-of-the-way areas where experience has shown no protection is required.

1. Protection Required:
 - a. Where tubing is concealed and support points of penetration are less than 2 inches from any outside edge of a stud, joist, plate, etc., shielding is required at the area of support and within 2 inches of each side (if appropriate) of the area of support. ([Figure 3.6](#)).
 - b. Where tubing is concealed and constrained to run less than 2 inches from wallboard or ceiling surfaces, it should be protected with a striker plate throughout the area of support. ([Figure 3.7](#)).
 - c. Where the tubing passes through a fire stop, pack the space around the tubing with approved fire stopping material.
2. No Protection Required:
 - a. Where tubing is concealed and tubing support points and points of penetration are greater than 2 inches from any outside edge of a stud, joist, plate, etc., or wall surface.
 - b. Where any non-restrained or non-fixed concealed tubing can be displaced in the direction of potential penetration at least 2 inches.
 - c. Where tubing is supported under the joists in basements or crawl spaces and is not concealed by wallboard or ceilings.
 - d. Where tubing is not concealed.

Figure 3.6: Construction Requiring Protection (Wall)

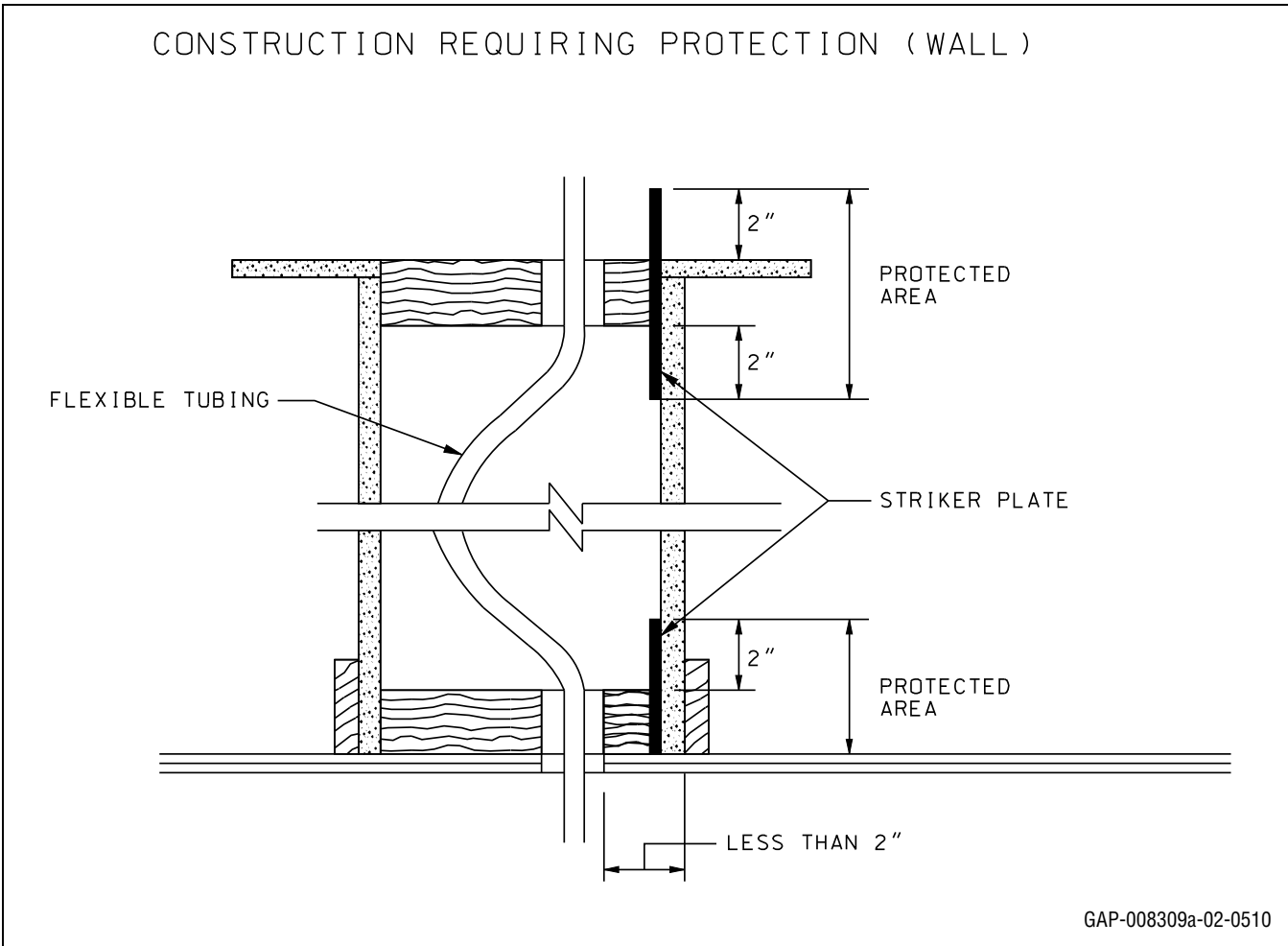
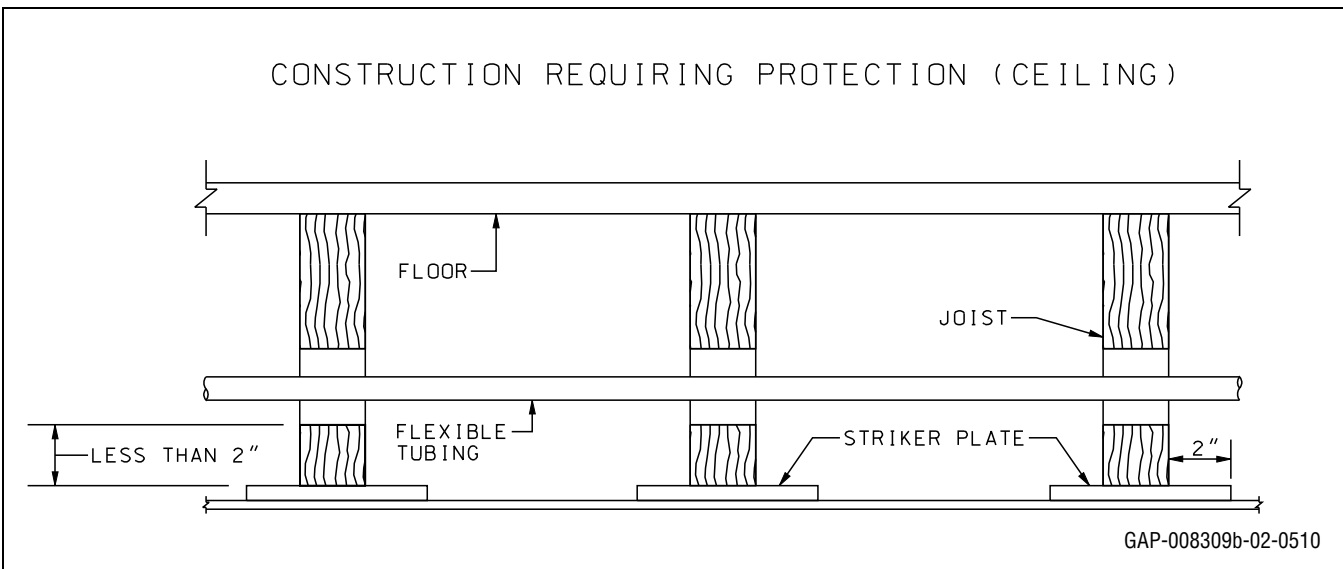

Figure 3.7: Construction Requiring Protection (Ceiling)



2.4 Pressure Testing and Inspection Procedure

The final installation shall be inspected and tested for leaks at 1-1/2 times the maximum working pressure, but not less than 3 PSIG, using procedures specified in the BOCA International Mechanical Code and in Part 4 “Inspection, Testing, and Purging” of the *International Fuel Gas Code*, and by local BOCA code official or authority having jurisdiction.

2.4.1 Initial Pressure Test

Pressure testing should be performed during rough construction of the facility before interior walls are finished. This will permit a more complete inspection of the piping system during the pressure testing.

In addition, the internal house tubing should be inspected to ensure:

- Presence of striker plates and other protective devices at all required locations.
- Physical conditions of the tubing.
- Presence of only approved fittings and joining connections.
- Proper labeling procedures.

2.4.2 Final Pressure Test

The final pressure test shall be performed after the final construction is complete and finished interior walls are in place. This test is performed to assure no damage was done to the tubing during the closing-in construction process.

All tests must be approved by local BOCA code officials or authority having jurisdiction.

This Page Intentionally Blank

Chapter 4 – Appliance Installation

1 General

1.1 Appliances, Accessories and Equipment to be “Approved”

All of the gas appliances and accessories referred to herein shall be design-certified by a nationally recognized testing agency such as American Gas Association Laboratories or Underwriters Laboratories as complying with the applicable American National Standards and shall also be approved by PSE&G.

1.2 Type of Gas

It shall be determined whether the appliance has been designed for use with the gas to which it will be connected. No attempt shall be made to convert the appliance from the gas specified on the rating plate for use with a different gas without consulting PSE&G or the appliance manufacturer for complete instructions.

1.3 Gas Pressure Booster

If the customer’s piping or equipment is equipped with a gas pressure booster:

1. A check valve shall be installed on the booster inlet piping to prevent a back pressure, and
2. A low pressure shutoff device shall be installed between the booster and the gas meter(s) to provide protection against a dangerous reduction in gas pressure. Such devices include, but are not limited to:
 - a. Mechanical, diaphragm, or electrically operated shutoff valves, or,
 - b. Low pressure switch (manual reset type) wired directly to the booster.

Note



To eliminate momentary low pressures caused by booster start-up, the low pressure switch should be located a minimum of 10 ft upstream from the booster. A flow restrictor (orifice) in the pressure switch connection may also be necessary to dampen the initial surge. The low pressure cut-off point should be based on the system type:

- Utilization Pressure (**UP**) system: Set cutoff pressure switch to open at 3 inches wc.
- Pressure system: Set cutoff switch to a setting specified by PSE&G.

1.4 Back Pressure Protection

If the gas utilization equipment is such that a back pressure might be produced, a check valve or equivalent shall be installed downstream of the meter installation to protect the system. If it is connected to a source of pressurized air or oxygen, a combination flashback arrestor and backflow check valve shall be installed on both the natural gas and the oxygen supply lines to ensure safe operation of all devices, equipment, and systems, including the gas meter.

1.5 Flammable Vapors or Dusts and Halogenated Hydrocarbons

The following details the requirements regarding the installation of gas appliances when flammable vapors or dusts and halogenated hydrocarbons are likely to be present:

1. Gas appliances shall not be installed in any location where flammable vapors or dusts are likely to be present, unless the design, operation and installation are such as to eliminate the possible ignition of the

flammable vapors or dust. Examples of such locations are paint spray rooms, wood working shops, and gasoline service station buildings in which gasoline pumps are housed and operated, or in which open gasoline vats or containers are used for parts cleaning.

- a. Gasoline station buildings in which the only operations consist of such things as lubrication, washing, motor tune-ups, wheel alignment, miscellaneous adjustments and minor repairs are exempt from the restriction in [Chapter 4, Section 1.5](#).
 - b. Wood working shops in which a dust collecting system is provided for wood working machines are exempt from the restriction in [Chapter 4, Section 1.5](#).
2. Gas appliances shall not be installed in any location where halogenated hydrocarbons are likely to be present in the combustion air. Such locations would include areas where adhesives, dry cleaning fluids, degreasing solutions, paint removers, hair sprays and pressure can propellants are used. To avoid or minimize corrosion problems, the following alternatives should be considered.
- a. Use appliances designed to, and which do, take all air from outdoors.
 - b. Locate appliances in a room, with an outdoor air intake, completely sealed off from work room space.
 - c. Locate appliances in a room pressurized with non-contaminated outdoor air.
 - d. Use outdoor appliances located away from contaminated air discharges.

1.6 Air for Combustion and Ventilation

The following details the requirements regarding Air for Combustion and Ventilation:

1. The provisions of *International Fuel Gas Code*, Section 304 shall apply to gas utilization equipment, installed in buildings, that require air for combustion, ventilation, and dilution of flue gases to be drawn from within the building.
2. Equipment shall be located so as not to interfere with proper circulation of combustion, ventilation, and dilution air. Where normal infiltration does not provide the necessary air, outside air shall be introduced.
3. A draft hood or a barometric draft regulator shall be installed in the same room or enclosure as the equipment in such a manner as to prevent any difference in pressure between the hood or regulator and the combustion air supply.
4. Air for combustion, ventilation, and dilution of flue gases for gas utilization equipment vented by natural draft shall be obtained by application of methods listed in *International Fuel Gas Code*, Section 304.
5. Air requirements for the operation of exhaust fans, kitchen ventilation systems, clothes dryers, and fireplaces shall be considered when determining the adequacy of a space to provide combustion air requirements.

2 Accessibility and Clearance

2.1 Accessibility for Service

The following provides the specifications regarding accessibility for service and clearance requirements:

1. Every gas appliance shall be located with respect to building construction and other equipment so as to permit access to the appliance. Sufficient clearance shall be maintained to permit cleaning of heating surfaces; the replacement of filters, blowers, motors, burners, controls and vent connections; the

lubrication of moving parts where necessary; and the adjustment and cleaning of burners and pilots. For attic installation the passageway and servicing area adjacent to the appliance shall be floored.

2. To provide for reasonable conditions of accessibility the following minimum specifications covering equipment location and clearances shall be observed:
 - a. Basement or Utility Room Installations:
 - i. The minimum clearance between the sides of a gas appliance and the adjacent wall or another appliance shall be the greater of the manufacturer's specification or:
 - 24 inches – at sides where access is required for servicing or cleaning.
 - 18 inches – at sides where access is required for passage to a side requiring servicing or cleaning.
 - 18 inches – at sides where access is required for inspection or replacement of the draft hood and vent connector.See [Figure 4.1](#) and [Figure 4.2](#).
 - ii. In utility room installations, the door shall be wide enough to allow the largest appliance part to enter, or to permit the replacement of another appliance, such as a gas water heater.
 - iii. Where there is only one appliance in the utility room, where proper fire hazard clearances have been provided, and the installation is such that there is complete accessibility for servicing and cleaning of the appliance and its vent connector through the door or through a property located removable access panel in a partition, the installation may be considered as complying with all necessary accessibility requirements.
 - b. Crawl Space Installations
 - i. The minimum clearance shall be:
 - 48 inches – between the ground or bottom of the pit and overhead construction.
 - 24 inches – at sides or bottom of the appliance where access is required for servicing or cleaning.
 - 18 inches – at sides where access is required for passage to a side requiring servicing or cleaning.
 - 18 inches – at sides where access is required for inspection or replacement of the draft hood and vent connector.
 - 6 inches – between the bottom of the appliance and the ground or bottom of the pit where access is not required for servicing or cleaning (See [Figure 4.3](#) and [Figure 4.4](#).)

Note  While these drawings indicate use of a common chimney or vent, in some cases it may be necessary to separately vent certain gas appliances. The installer should refer to the manufacturer's instructions.

- ii. The ground surface of the service area and passageway shall be dry. If excavated, the service area and passageway shall be surfaced with 4 inches of washed gravel or its equivalent. If the bottom of the gas appliance is less than 6 inches above general ground level in crawl space, or if water seepage is likely, a waterproof pit with a rim 4 inches above ground level shall be provided. (See [Figure 4.4](#).)
- iii. The access door or other means of entry to the crawl space shall not be less than 24 inches x 36 inches, but in any case shall be large enough to allow the largest appliance part to

enter. The passageway from the point of entry to the service area shall be at least 24 inches wide and 48 inches high. Where a trap door is used a permanent ladder shall be installed.

iv. A fixed electric light shall be installed near the furnace.

c. Attic Installations:

i. See [Figure 4.5](#). The minimum clearance shall be:

48 inches – between the floor and overhead construction where access is required for servicing or cleaning.

24 inches – at sides of the appliance where access is required for servicing or cleaning.

18 inches – at sides of the appliance where access is required for passage to a side requiring servicing or cleaning.

18 inches – at sides where access is required for inspection or replacement of the draft hood and vent connector. (See [Figure 4.5](#).)

ii. The access door or other means of entry to the attic should not be less than 20 inches x 30 inches, but in any case shall be large enough to allow the largest appliance part to enter. The passageway from the point of entry to the service area shall be at least 24 inches wide and 48 inches high. Access to the attic shall be by means of permanent or foldaway stairway, permanent or portable ladder, or a step ladder.

iii. All attic passageways and service areas shall be covered with flooring not less than 24 inches wide.

iv. A fixed electric light shall be installed near the appliance.

Figure 4.1: Examples of Minimum Basement or Utility Room Clearances

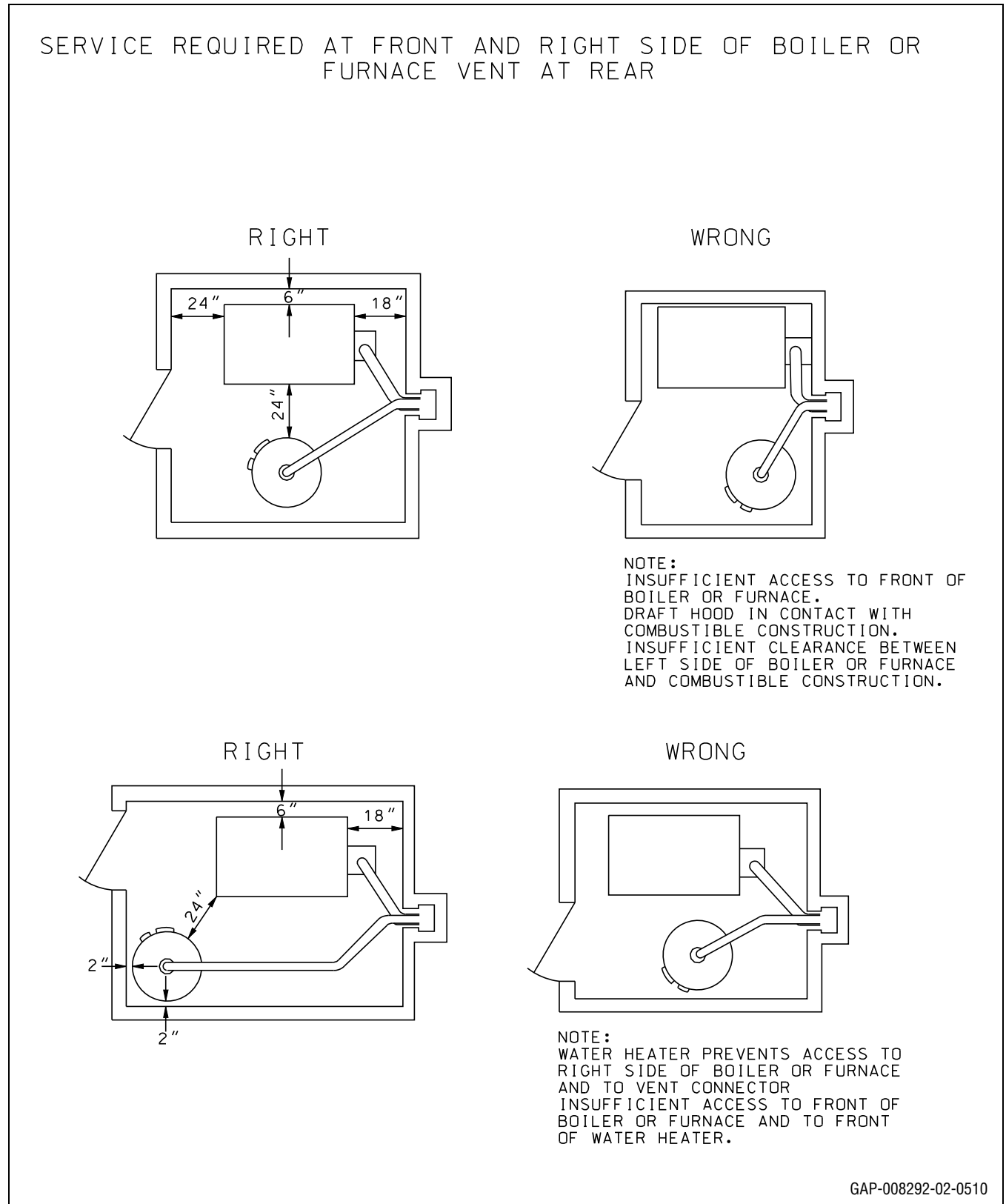
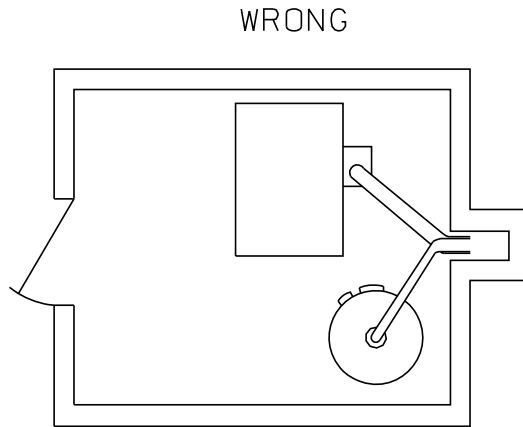
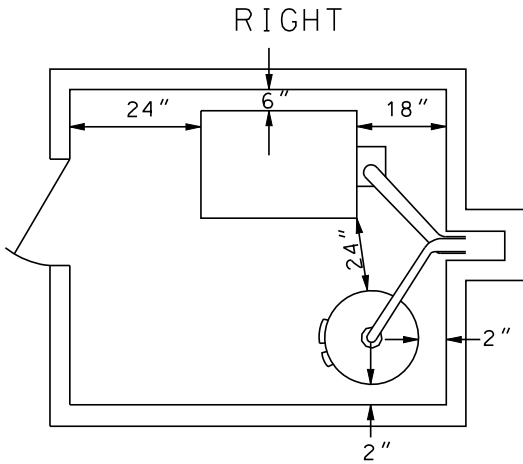

Figure 4.2: Examples of Minimum Basement or Utility Room Clearances (2)

A. SERVICE REQUIRED AT FRONT OF BOILER OR FURNACE
VENT AT REAR



NOTE:
INSUFFICIENT ACCESS TO VENT
CONNECTOR AND FRONT OF WATER
HEATER.
BOILER OR FURNACE OBSTRUCTS
ACCESS FOR REMOVAL OF WATER
HEATER.

B. SERVICE REQUIRED AT FRONT OF BOILER OR FURNACE
VENT AT TOP

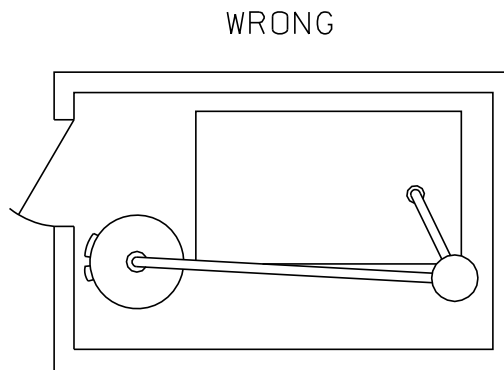
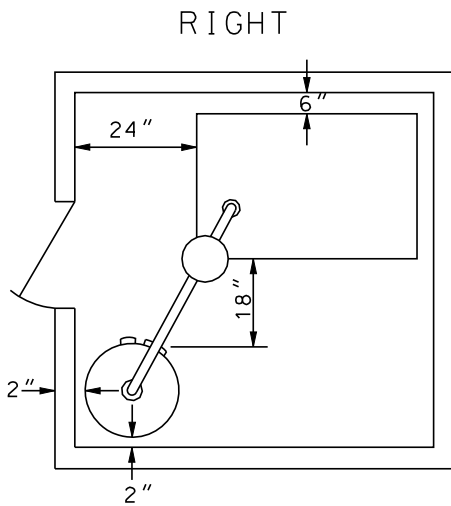

NOTE:
VENT CONNECTOR INACCESSIBLE. ACCESS
TO FRONT OF BOILER OR FURNACE PARTIALLY
BLOCKED BY WATER HEATER.
INSUFFICIENT CLEARANCE FOR SERVICING
OF WATER HEATER.

GAP-008293-02-0510

Figure 4.3: Examples of Minimum Crawl Space Clearances

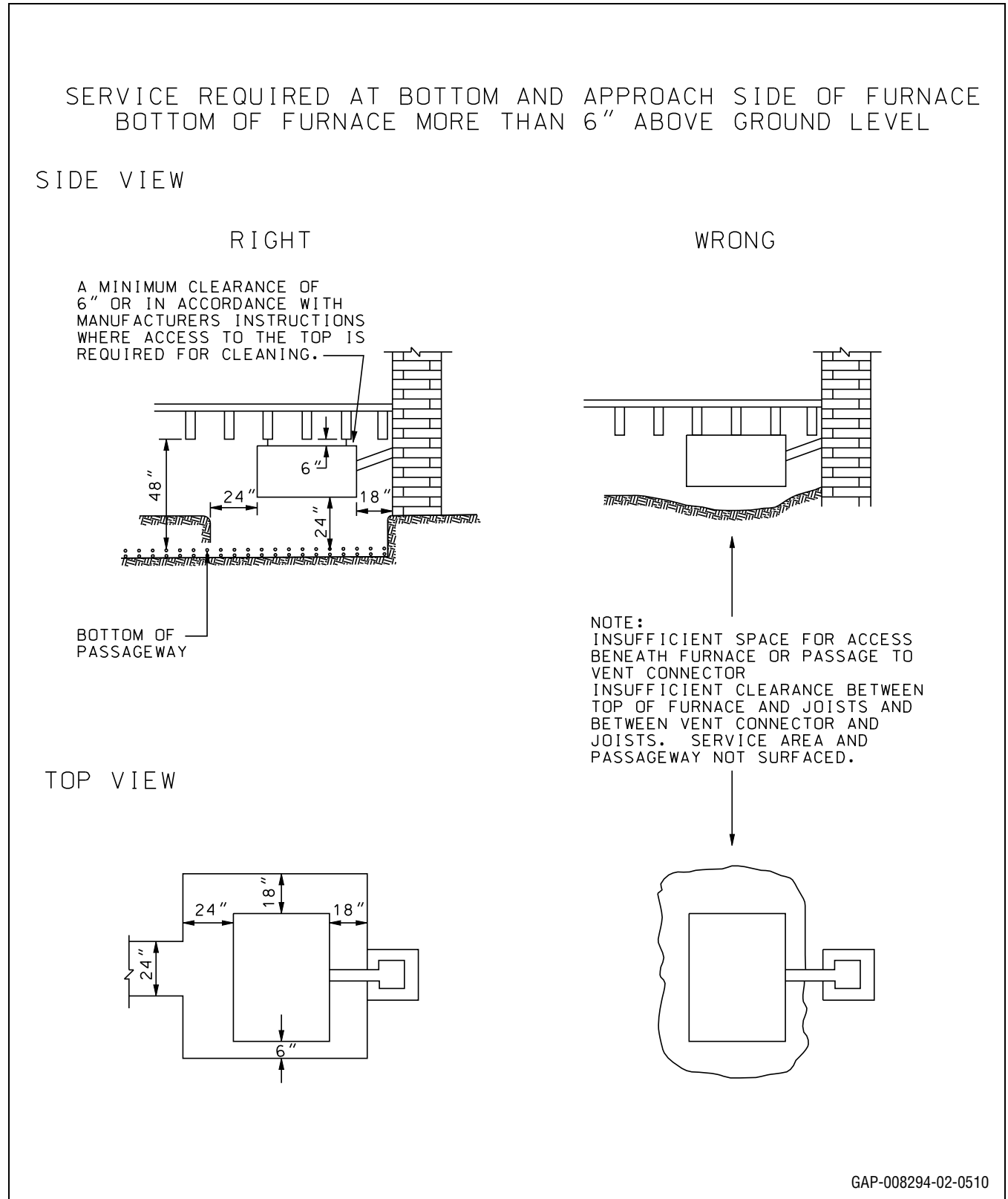

Figure 4.4: Examples of Minimum Crawl Space Clearances (2)

SERVICE REQUIRED AT APPROACH SIDE OF FURNACE ONLY
 BOTTOM OF FURNACE MORE THAN 6" ABOVE GROUND LEVEL

SIDE VIEW

RIGHT

A MINIMUM CLEARANCE OF 6" OR IN ACCORDANCE WITH MANUFACTURERS INSTRUCTIONS WHERE ACCESS TO THE TOP IS REQUIRED FOR CLEANING.

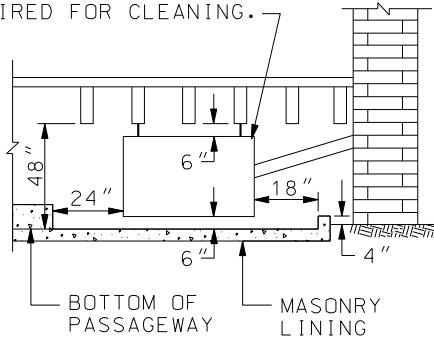

WRONG

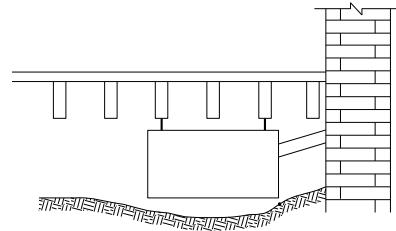

NOTE:
 VENT CONNECTOR TOO CLOSE TO JOIST.
 PIT AND PASSAGEWAY NOT WATER-PROOFED.
 INSUFFICIENT ACCESSIBILITY CLEARANCE.

TOP VIEW

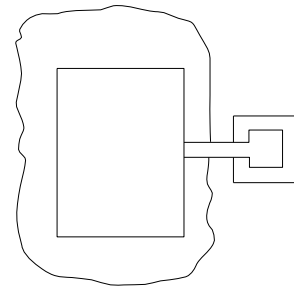
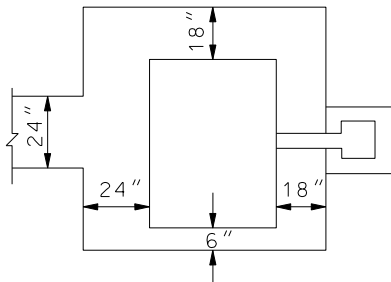

GAP-008295-03-0710

Figure 4.5: Examples of Minimum Attic Clearances

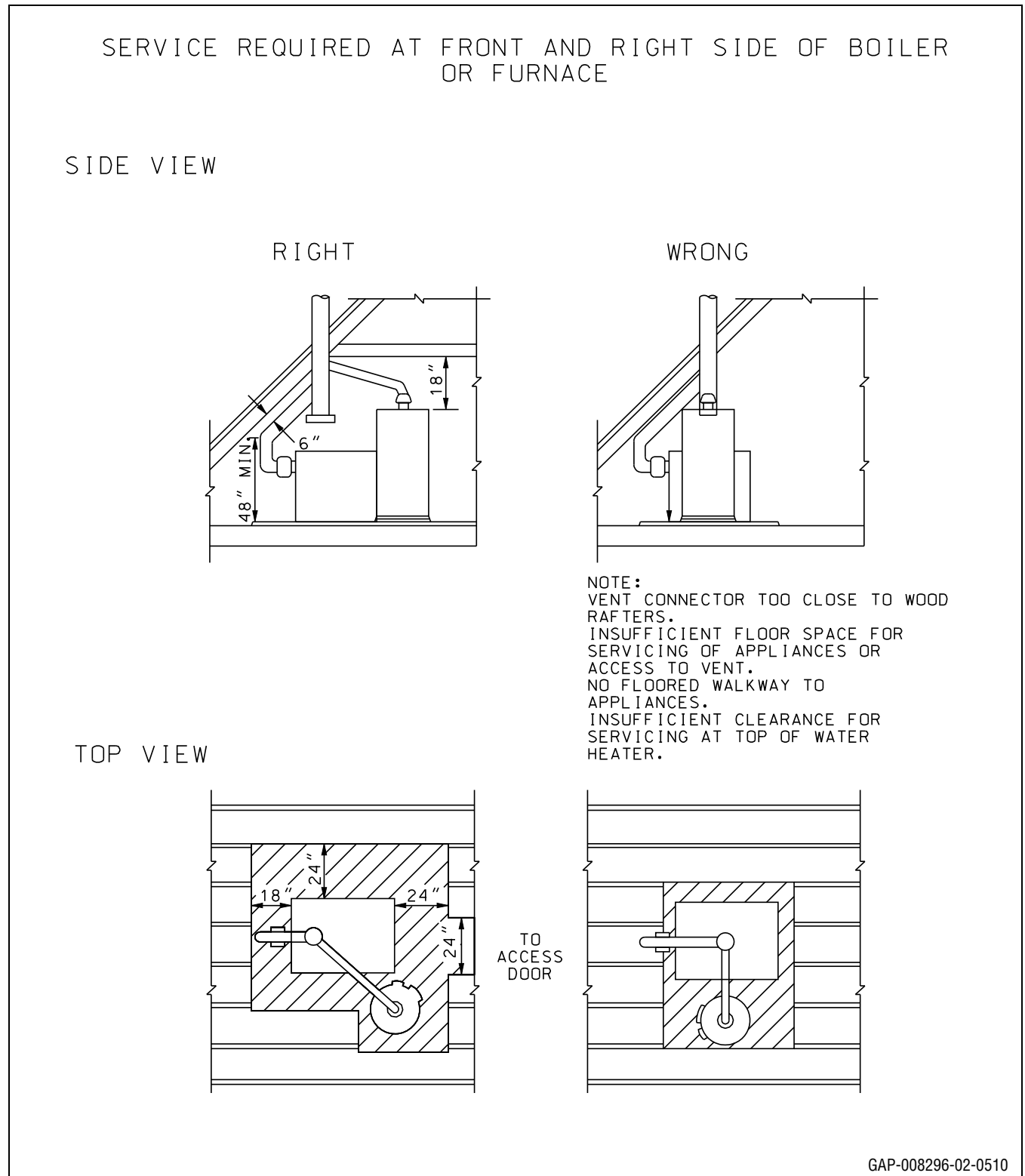

2.2 Access to Suspended Gas Appliances

The following provides the specifications regarding access to suspended gas appliances:

1. A safe means of access to suspended type appliances shall be provided by the customer.
2. Access to any suspended appliance more than 15 ft above the floor or ground shall be provided by any one of the following methods:
 - a. A permanent stairway terminating at a fixed platform.
 - b. A manually propelled mobile stand or scaffold.
 - c. A fork lift truck platform or work stage.
3. Access to any suspended appliance 15 ft or less above the floor or ground shall be provided by any one of the methods in [Section 2.2.](#), item 2 above or any one of the following methods:
 - a. A step ladder.
 - b. A single section ladder.
 - c. An extension ladder.
 - d. A platform ladder.
 - e. A ladder terminating at a fixed platform.
4. Portable ladders shall be of adequate height to safely reach and service the appliance.
5. If sufficient or adequate building structural members are not present, or are not properly positioned to hold a portable ladder in a fixed position when servicing the appliance, the top section of portable ladders shall be equipped with hooks and ladder supports as follows:
 - a. The supports shall be constructed separately from appliance supports and hangers.
 - b. The ladder support bar shall be positioned approximately 2 ft above the appliance.
 - c. The supports shall be so constructed that they will safely support the ladder and serviceperson.
 - d. The supports shall be so constructed that the ladder can not slip off either end of the support.
6. Construction of the means of access should comply with all Federal and State Standards. References may be made to Appendix C for pertinent specifications of the Occupational Safety and Health Administration (**OSHA**) with respect to the construction of the means of access and the care and use of ladders, and for drawings of suggested methods for complying with the provisions of this section.

3 Appliances on Roofs

3.1 General

The following provides general information regarding appliances on roofs:

1. Appliances shall be designed or enclosed so as to withstand climatic conditions in the area in which they are installed. If enclosures are provided, each enclosure shall permit easy entry and movements, shall be of reasonable height, and shall have at least 2 ft. clearance to either side of the service access panel(s) of the appliance(s) in the enclosure.
2. Roofs on which appliances are to be installed shall be capable of supporting the additional load or shall be reinforced to support the additional load:

3. All access locks, screws and bolts shall be of corrosion-resistant material.
4. Protection from weather should be provided by the appliance itself or by an enclosure for the service person working in the location accessible to the controls, burner, and pilots.

3.2 Installation

The following details the installation requirements for appliances on roofs:

1. Appliances shall be installed in accordance with this manual, their listing and the manufacturer's installation instructions.
2. Appliances shall be installed on a well drained surface. At least 6 ft clearance shall be available between the appliance and the edge of a roof or similar hazard, or rigidly fixed rails or guard at least 42 inches in height shall be provided on the exposed rail. A parapet or building structure at least 42 inches in height may be utilized in lieu of rails or guards. The sides of appliances requiring access for servicing shall be located at least 2 ft from railings, parapets, walls, chimneys, skylights or other obstructions.
3. Each appliance requiring an external source of electrical power for its operation shall be provided with an accessible electrical disconnect means near the appliance. A 110-120 AC volt grounding type convenience outlet shall be provided on the supply side of the disconnect switch.
4. When water stands on the roof at the appliance or in the passageways to the appliance, or when the roof is of a design having a water seal, a suitable platform or walkway or both shall be provided above the water line. Such platform(s) or walkway(s) shall be located adjacent to the appliance and control panel so that the appliance can be safely serviced when water stands on the roof.
5. The roof surface around and to the appliance shall be durable and suitable in all weather for walking on without sticking to service person's shoes or damaging the roof. Suitable platform(s) or walkway(s) or both should be provided so that the appliance can be safely reached and serviced.

3.3 Access to Appliances

The following provides the requirements for accessing appliances on roofs:

1. A safe means of access to appliances located on roofs or other elevated locations shall be provided by the customer.
2. Access to the roofs of buildings exceeding 24 ft in height shall be provided by any one of the following methods:
 - a. Inside permanent or foldaway stairway, terminating in an enclosure, scuttle or trap door.
 - b. Outside stairway or ramp.
 - c. Inside portable ladder terminating in a scuttle or trap door if the scuttle or trap door is not more than 15 ft above the floor upon which the ladder will rest.
3. Access to the roofs of buildings not exceeding 24 ft in height shall be provided by any one of the methods in [Section 3.3](#), item 2.c. above, or any one of the following methods.
 - a. Outside portable ladder.
 - b. Outside fixed metal ladder.
4. Scuttles or trap doors shall be at least 24 inches x 36 inches in size, and shall open easily and safely under all conditions especially snow, and shall be constructed so as to permit access from the roof side unless deliberately locked on the inside.

At least 6 ft clearance shall be available between the access opening and the edge of the roof or similar hazard, or rigidly fixed rails or guards at least 42 inches in height shall be provided on the exposed side. A mid-rail will be provided halfway between the roof and top rail. A parapet or other building structure at least 42 inches in height may be utilized in lieu of guards or rails.

5. Proper permanent lighting shall be provided at the roof access. The switch for such lighting shall be located inside the building near the access means leading to the roof.
6. If sufficient or adequate building structural members are not present, or are not properly positioned to hold a portable ladder in a fixed position for climbing, the top section of portable ladders shall be equipped with hooks for attachment to building structural members. Portable ladders shall extend at least 3 ft above the point of support at eaves, gutter or roof line.
7. Construction of the means of access should comply with all Federal and State Standards. Reference may be made to Chapter 7 for pertinent specifications of the OSHA with respect to the construction of the means of access and the care and use of ladders, and for drawings of suggested methods of access to appliances.

3.4 Accessibility for Servicing

Controls, flue passages, burners, pilots, draft hoods, blowers, filters, and gas and electric connections of the unit shall be readily accessible without lying down, crawling or reaching more than 18 inches through restricted openings.

Chapter 5 – Installation of Specific Appliances

1 General

An appliance or an accessory should be listed by A.G.A. Laboratories or the equivalent and be installed according to its manufacturer's installation instructions and as elsewhere specified in this Chapter and in the Inspection Checklist included in [Chapter 8](#).

1.1 Multiple Appliances

Appliances in multiple dwelling installations shall be plainly and permanently marked by the installer, designating the building or the part of the building served by the appliance.

1.2 Continuous Power

Electrical connections shall be made directly from heating and air conditioning appliances to the main fuse or circuit breaker panel or to a separate fuse box directly connected to the main supply line. A low or line voltage service switch located on or adjacent to the appliance shall be provided to shut off electricity to all controls.

2 Central Heating Boilers and Furnaces

2.1 Equipment Sizing Procedure

The procedure for sizing residential gas heating equipment should be done in accordance with the Air Conditioning Contractors of America Manual J method or other industry recommended methods. Average single family heating equipment input requirements for a variety of building types in the mid Atlantic region are tabulated in [Chapter 6](#) and may be used as a preliminary check.

2.2 Forced Warm Air Heating Systems

The following provides information for the installation of forced warm air heating systems:

1. General
 - a. The installation should be designed in conformance with the methods recommended by the Air Conditioning Contractors of America and Pamphlet No. 90B of the National Fire Protection Association.
 - b. Return air shall be conducted to the furnace through continuous ducts, except that under floor spaces may be used for return of air from rooms directly above provided such spaces are not over 2 ft in height to bottom of floor joists and are cleared of all combustible material, are tightly and substantially enclosed and sealed against moisture gain from soil.
 - c. For systems using small ducts with high velocity air, some of these practices may not apply. In such cases, the duct manufacturer's instructions should be followed.
 - d. A plenum chamber supplied as a part of a furnace shall be installed in accordance with the manufacturer's instructions.
 - e. When a plenum chamber is not supplied with the furnace, any fabrication and installation instructions provided by the manufacturer shall be followed. The method of connecting supply and return ducts shall facilitate proper circulation of air.

- f. When a furnace is installed so that supply ducts carry air circulated by the furnace to areas outside the space containing the furnace, the return air shall also be handled by duct(s) sealed to the furnace casing and terminating outside the space containing the furnace.

2. Supply Ducts

- a. The duct system shall be reasonably air-tight.
- b. Supply plenum chamber and ducts shall be completely and tightly constructed of fireproof material.
- c. If supply risers are run in outside walls they should be installed on the three outer surfaces with sufficient insulation, which should be securely fastened in an approved manner.
- d. No duct shall have a transverse dimension (length or width) of less than 3 inches.
- e. It is not recommended that a garage be heated from the central heating warm air furnace, but if it is to be heated in this way, a separate branch shall be run directly from the furnace. The register shall be of the automatic back draft damper type. (See *Uniform Construction Code*.)
- f. All trunk ducts or branches run in unheated attics, garages, and similar spaces, shall be installed with sufficient insulation, which shall be securely fastened in an approved manner.
- g. All supply ducts shall be installed at least 1 inch from outside masonry walls.

3. Return Ducts

- a. No duct shall have a transverse dimension (length or width) of less than 3 inches.
- b. Where a supplementary outside cold air intake is used, it shall be equipped with a close-fitting damper and with an insect screen which should be readily accessible for cleaning. The cold air intake should be separately connected to the return air plenum. No reduction in return grille or duct area shall be made because of the use of the cold air intake.
- c. No return air shall be taken from a garage, bathroom, rooms of any toxic content, utility room, or basement sections not used as living quarters.

4. Dampers

Volume or stack head dampers with positive locking devices shall be installed in each branch. If volume dampers are used, they shall be installed in the branch adjacent to the trunk. Adjustable maximum opening registers may be considered as equivalent to stack head dampers.

5. Registers and Grilles

- a. Each room in which heat is desired shall be provided with at least one supply register.
- b. A separate return riser shall be provided for each return grille.

2.3 Steam Heating Systems

The following provides information for the installation of steam heating systems:

1. System Piping and Connections

- a. The installation should be installed in conformance with the methods recommended by the Hydronics Institute or other recognized authority.
- b. On boilers with only one outlet, the connection from the boiler to the steam main shall be the full size of the boiler tapping, or in accordance with the manufacturer's printed instructions.

A common header shall be used where there is more than one outlet, unless the manufacturer's printed instructions specify a single riser is adequate. The header size shall be at least equal to that given below or in accordance with the manufacturer's printed instructions.

Table 5-1: Boiler Input Rating vs Size of Header

Boiler Input Rating (BTU per Hour)	Size of Header (inches)
Less than 135,000	2
135,000 to 179,000	2-1/2
180,000 to 239,000	3
240,000 or over	Outlet Size

- c. In order to prevent water from leaving the boiler due to unequal pressures, a Hartford loop and equalizer connection shall be installed between the steam and return sides of the boiler. See [Figure 5.1](#) for acceptable methods of piping the Hartford loop and equalizer connection.
- d. Equalizer connections between the steam and return sides of the boiler shall be at least equal to the size given below.

Table 5-2: Boiler Input Rating vs Size of Equalizer

Boiler Input Rating (BTU per Hour)	Size of Equalizer (inches)
160,000 or less	1-1/4
160,100 to 200,000	1-1/2
200,100 to 440,000	2
440,100 to 750,000	2-1/2
750,100 to 1,150,000	3
More than 1,150,000	4

- e. A steam boiler shall be provided with a direct connection to a water supply through an individual control valve. A drain valve, by means of which the boiler may be flushed or drained, shall also be provided.
- f. The terminus of each steam supply main or each dry return shall be provided with a satisfactory air elimination device.
- g. Means shall be provided for draining all piping below the water line, either by the use of valves or tees fitted with nipples and caps. See [Figure 5.1](#).

2. Low Water Cutoff

Steam boilers shall be provided with an automatic means to shut off the fuel supply to the burner(s) if the boiler water level drops to the lowest safe water line.

3. Pressure Relief Valves

Steam boilers shall be equipped with listed or approved steam pressure relief valves of appropriate discharge capacity and conforming with ASME requirements. Steam pressure relief valves shall be set to discharge at a pressure not to exceed the maximum allowable working pressure of the boiler. Steam pressure relief valves shall not discharge so as to be a hazard, a potential cause of damage or otherwise a nuisance. Steam pressure relief valves shall have discharge piping installed not more than 6 inches above the floor. When a low-pressure steam pressure relief valve discharges to the draining system, it shall be installed in accordance with *National Plumbing Code*, Section 10.16.6.

Figure 5.1: Examples of Hartford Equalizer Connections

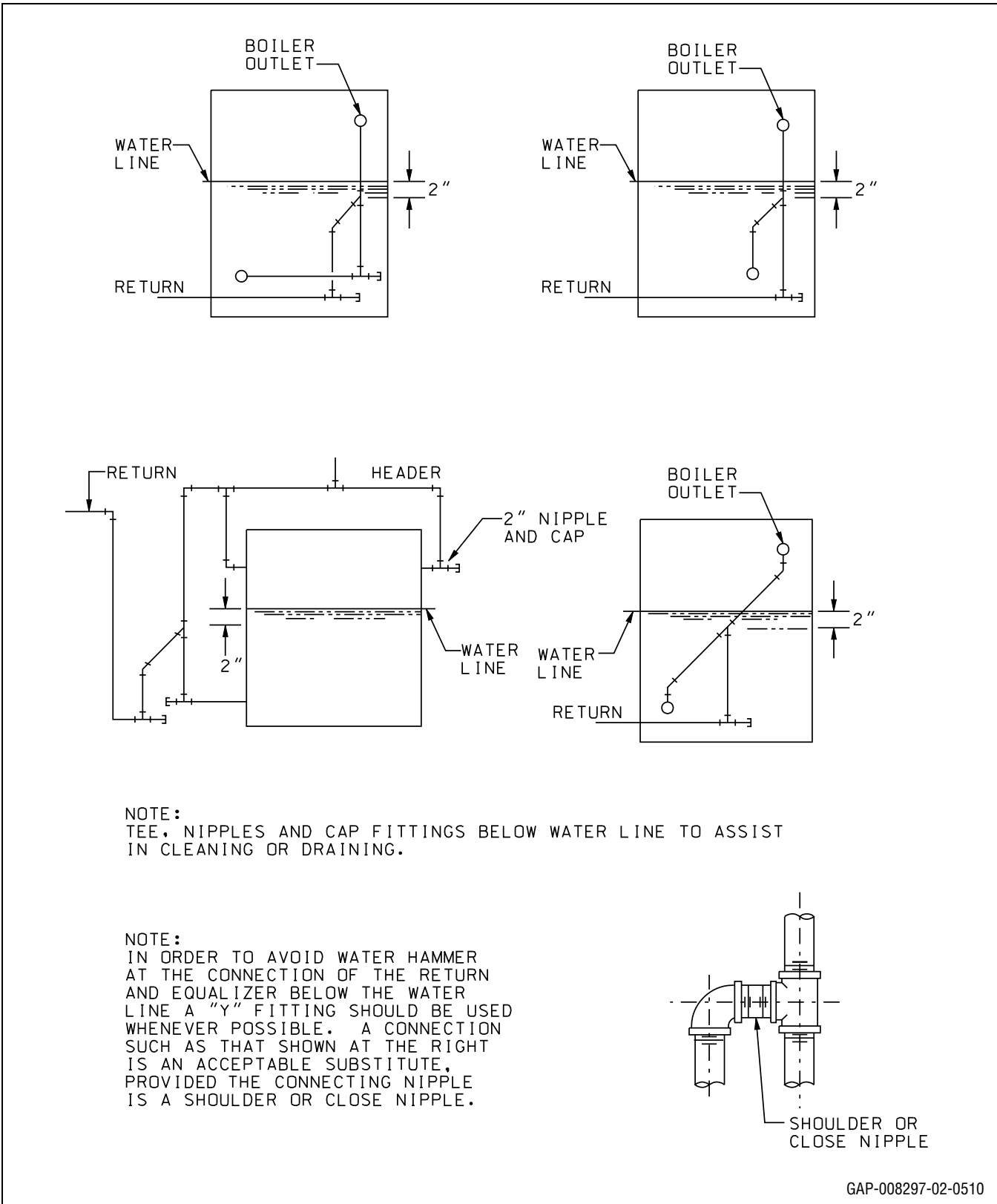

4. Pressure Limiting Devices

Steam boilers shall be provided with approved automatic limiting devices for shutting down the burner(s) to prevent boiler steam pressure from exceeding the maximum allowable working pressure.

5. Radiators and Convectors

- a. Each radiator or convector shall be provided with an air elimination device.
- b. A means for shutting off each radiator or convector shall be provided.

6. Boiler Cleaning

Upon completion of the installation, and as many times thereafter as conditions require, the boiler shall be blown down under steam pressure to insure the delivery of dry steam without foaming. The installer shall see that the entire system is free from dirt, oil or any foreign matter that may cause priming.

2.4 Hot Water Heating Systems

The following provides information for the installation of hot water heating systems:

1. System Piping and Connections

- a. The installation should be installed in conformance with the methods recommended by the Hydronics Institute or other recognized authority.
- b. All piping shall be so pitched that air in the system can be vented either through an open expansion tank, radiators, or an automatic vent valve.
- c. A closed system shall be provided with an expansion tank with means for air recharging.
- d. A hot water boiler shall be provided with a direct connection to a water supply through an individual control valve. A drain valve, by means of which the boiler may be flushed or drained, shall also be provided.

2. Temperature Limiting Devices

Hot water boilers shall be provided with approved automatic limiting devices for shutting down the burner(s) to prevent boiler water temperature from exceeding the maximum allowable working temperature.

3. Pressure Relief Valves

Hot water boilers shall be equipped with listed or approved pressure relief valves of appropriate discharge capacity and conforming with ASME requirements. Pressure relief valves shall be set to discharge at a pressure not to exceed the maximum allowable working pressure of the boiler. Pressure relief valves shall not discharge so as to be a hazard, a potential cause of damage or otherwise a nuisance. Pressure relief valves shall have discharge piping installed not more than 6 inches above the floor. When a low pressure relief valve discharges to the drainage system, it shall be in accordance with National Plumbing Code Section 10.16.6.

4. Low Water Cutoff

All steam and hot water boilers shall be protected with a low-water cutoff control. The low-water cutoff shall automatically stop the combustion of the appliance when the water level drops below the lowest safe water level as established by the manufacturer.

5. Radiators and Convectors

Each radiator or convector shall be provided with an air elimination device and it should be readily accessible.

2.5 Refrigeration Coils

Refrigeration coils shall be installed in parallel with or on the downstream side of central furnaces to avoid condensation in the heating element unless the furnace has been specifically listed for downstream installation. With a parallel flow arrangement, the dampers or other means used to control flow of air shall be sufficiently tight to prevent any circulation of cooled air through the furnace.

When hot water heating boilers are connected to heating coils located in air handling units where they may be exposed to refrigerated air circulation, such boiler piping systems shall be equipped with flow control valves or other automatic means to prevent gravity circulation of the boiler water during the cooling cycle.

2.6 Masonry Chimneys

The following provides additional information regarding masonry chimneys:

1. External Chimneys with Fan-Assisted Appliances:

Venting a fan-assisted appliance without at least one additional draft hood equipped appliance into an external chimney requires the chimney be relined with a type “B” double wall vent or listed flexible chimney lining system. PSE&G strongly recommends that fan assisted appliances commonly vented with other draft hood equipped appliances into external chimneys also be connected to a type “B” double wall vent or a suitable flexible chimney lining system. Refer to *International Fuel Gas Code*, Table 504.2(3) for venting equipment using external masonry chimneys.

Note



For use with this supplement, External Masonry Chimneys are defined as masonry chimneys exposed to the outdoors on one or more sides below the roof line. Refer to *International Fuel Gas Code*, Chapter 2 Definitions.

2. Chimneys in Gas Conversions:

A chimney to be used for venting a gas appliance shall be cleaned if previously used for venting solid or liquid fuel appliances or fireplaces.

3 Gas Ranges

3.1 Anti-Tipping Devices

Gas ranges should be installed with anti-tipping devices specified by the gas range manufacturer.

Chapter 6 – Single-family Heating Equipment Input Requirements

Table 6-1: Single-family Heating Equipment Input Requirements

	Housing Type	Pre-1918				Post-1918				1980's	
		As-Built		Insulated		As-Built		Insulated			
		AFUE	80%	90%	80%	90%	80%	90%	80%	90%	80%
Square Footage	1	56.7	49.6	40.9	35.8	42.9	37.5	33.9	29.7	23.4	20.5
	700	39714	34750	28643	25063	30000	26250	23724	20759	16364	14318
	800	45388	39714	32735	28643	34286	30000	27114	23724	18701	16364
	900	51061	44679	36827	32223	38571	33750	30503	26690	21039	18409
	1000	56735	49643	40918	35804	42857	37500	33892	29656	23377	20455
	1100	62408	54607	45010	39384	47143	41250	37281	32621	25714	22500
	1200	68082	59571	49102	42964	51429	45000	40671	35587	28052	24545
	1300	73755	64536	53194	46545	55714	48750	44060	38552	30390	26591
	1400	79429	69500	57286	50125	60000	52500	47449	41518	32727	28336
	1500	85102	74464	61378	53705	64286	56250	50838	44483	35065	30682
	1600	90776	79429	65469	57286	68571	60000	54227	47449	37403	32727
	1700	96449	84393	69561	60866	72857	63750	57617	50415	39740	34773
	1800	102122	89357	73653	64446	77143	67500	61006	53380	42078	36818
	1900	107796	94321	77745	68027	81429	71250	64395	56346	44416	38864
	2000	113469	99286	81837	71607	85714	75000	67784	59311	46753	40909
	2100	119143	104250	85929	75188	90000	78750	71173	62277	49091	42955
	2200	124816	109214	90020	78768	94286	82500	74563	65242	51429	45000
	2300	130490	114179	94112	82348	98571	86250	77952	68208	53766	47045
	2400	136163	119143	98204	85929	102857	90000	81341	71173	56104	49091
	2500	141837	124107	102296	89509	107143	93750	84730	74139	58842	51136
2600	147510	129071	106388	93089	111429	97500	88120	77105	60779	53182	
2700	153184	134036	110480	96670	115714	101250	91509	80070	63117	55227	
2800	158857	139000	114571	100250	120000	105000	94898	83036	65455	57273	
2900	164531	143964	118663	103830	124286	108750	98287	86001	67792	59318	

Table 6-1: Single-family Heating Equipment Input Requirements (Cont'd)

	Housing Type	Pre-1918				Post-1918				1980's	
		As-Built		Insulated		As-Built		Insulated			
		AFUE	80%	90%	80%	90%	80%	90%	80%	90%	80%
Square Footage	3000	170204	148929	122755	107411	128751	112500	101676	88967	70130	61364
	3100	175878	153893	126847	110991	132857	116250	105066	91932	72468	63409
	3200	181551	158857	130939	114571	137143	120000	108455	94898	75805	65455
	3300	187224	163821	135031	118152	141429	123750	111844	97864	77143	67500
	3400	192898	168786	139122	121732	145714	127500	115233	100829	79481	69545
	3500	198571	173750	143214	125313	150000	131250	118622	103795	81818	71591
	3600	204245	178714	147306	128893	154286	135000	122012	106760	84156	73636
	3700	209918	183679	151398	132473	158571	138750	125401	109726	86494	75682
	3800	215592	188643	155490	136054	162857	142500	128790	112691	88831	77727
	3900	221265	193607	159582	139634	167143	146250	132179	115675	91169	79773
	4000	226939	198571	163673	143214	171429	150000	135569	118622	93506	81818
	4100	232612	203536	167765	146795	175714	153750	138958	121588	95844	83864
	4200	238286	208500	171857	150375	180000	157500	142347	124554	98182	85909
	4300	243959	213464	175949	153955	184286	161250	145736	127519	100519	87955
	4400	249633	218429	180041	157536	188571	165000	149125	130485	102857	90000
	4500	255306	223393	184133	161116	192857	168750	152515	133450	105195	92045
	4600	260980	228357	188224	164696	197143	172500	155904	136416	107352	94091
	4700	266653	233321	192316	168277	201429	176250	159293	139381	109870	96136
	4800	272327	238286	196408	171857	205714	180000	162682	142347	112208	98182
	4900	278000	243250	200500	175438	210000	183750	166071	145312	114545	100227
5000	283673	248214	204592	179018	214286	187500	169461	148278	116883	102273	

Chapter 7 – Construction Specifications – Suspended and Roof Installed Appliances

1 Ladder Safety

1.1 Ladder Condition

In every case prior to using a ladder the following inspections must be made:

1. Are the rungs or steps in good, sound condition? Are they cracked, broken, or loose? Are there any repaired or makeshift rungs or steps?
2. Are the side rails free of splinters, cracks or splits? Are they warped or bent? Do the rails have non-slip base attachments (shoes)?
3. Stepladders should be opened and checked for loose or bent hinge spreaders or other defective hardware.
4. Extension ladders should be checked for loose, broken or missing guides, pulleys, screws or bolts. Is the rope frayed, knotted or unsafe because of a dry-rot condition?

Where any of the above inspections disclose an unsafe condition, correction should be made or a replacement ladder secured before being used. The unsafe ladder should be taken out of service using the Defective Equipment Tag.

Figure 7.1: Defective Equipment Tag (PSE&G Form 95-5454)



2 Access to Suspended Appliances

2.1 Fixed Platforms

See [Figure 7.2](#).

Fixed platforms should comply with Occupational Safety & Health Administration (**OSHA**) Standard 1910.28, Safety requirements for scaffolding, with a preferred minimum width of 36 inches and constructed on each side of the appliance which requires service accessibility.

Guarding of platforms, railings and toeboards should be built in accordance with OSHA Standard 1910.23, Guarding floor and wall openings and holes.

1. Rigid guard rails shall be installed no less than 36 inches and no more than 42 inches at all open sides of the platform and intermediate rails shall be provided halfway between the platform and top railing.
2. A 4 inch toeboard should be provided around the edge of the platform.
3. A wire screen of No. 18 U.S. Standard gage wire with a 1/2 inch mesh, or equivalent should be installed from the toeboard to the top railing to protect against falling objects.
4. Wooden railings and posts shall be at least 2 inch x 4 inch stock with posts spaced not more than 6 ft apart. Mid railing shall be at least 1 inch by 4 inch stock.
5. Pipe railings and posts should be at least 1-1/2 inches nominal diameter with posts spaced not more than 8 ft on centers.
6. Structural steel railings and posts should be 2 inches x 2 inches x 3/8 inch angles or other metal shapes of equivalent bending strength with posts spaced not more than 8 ft on centers.

2.2 Stairways

See [Figure 7.2](#).

Stairways should be built in accordance with OSHA Standard 1910.24, Fixed industrial stairs and National Fire Protection Association No. 101, Life Safety Code.

1. The angle of the stairway should be between 30 and 50 degrees with the horizontal.
2. The minimum tread width should be 22 inches.
3. Treads less than 9 inches deep should have an open riser as a preferred design.
4. Railings should be provided on the open sides not more than 34 inches nor less than 30 inches above the surface of the tread.
5. Vertical clearance above an overhead stair tread to an overhead obstruction shall be at least 7 ft measured from the leading edge of the tread.

2.3 Mobile Stands or Scaffolds

See [Figure 7.3](#).

Manually propelled mobile stands or scaffolds should be built and used in accordance with OSHA Standard 1910.29, Manually propelled mobile ladder stands and scaffolds (towers).

1. The maximum work level height should not exceed four times the minimum or least base dimension of the stand or scaffold. Outriggers may be used to achieve a larger base dimension.

2. The platform width for any work level should not be less than 36 inches as a preferred design.
3. All work levels 10 ft or higher above the ground or floor should have standard (4 inch nominal) toeboard.
4. All work levels should have a guardrail of 2 inch x 4 inch nominal lumber or the equivalent installed no less than 36 inches or more than 42 inches high with a midrail of 1 inch x 4 inch nominal lumber or equivalent.

A stairway should be provided for proper access and egress, and should be affixed to or built into the stand or scaffold and so located that its use will not have a tendency to tip the stand or scaffold. Landing platforms should be provided at intervals not to exceed 30 ft. If the platform is not more than 15 ft above the ground or floor, a fixed ladder may be used in place of a stairway.

1. Steps should have a minimum width of 16 inches.
2. Stairways having more than a 60 inch rise or 5 steps should be equipped with a handrail at least 29 inches high.
3. Fixed ladders should comply with [Section 2.5.4](#) of this chapter.

All stands or scaffolds should have locking casters or other means of locking the unit in position and at least two of the four casters should be of the swivel type. Stands or scaffolds should not be moved when a serviceman is on the platform.

Figure 7.2: Suspended Unit Accessing Using Stairway or Ladder Terminating at a Platform

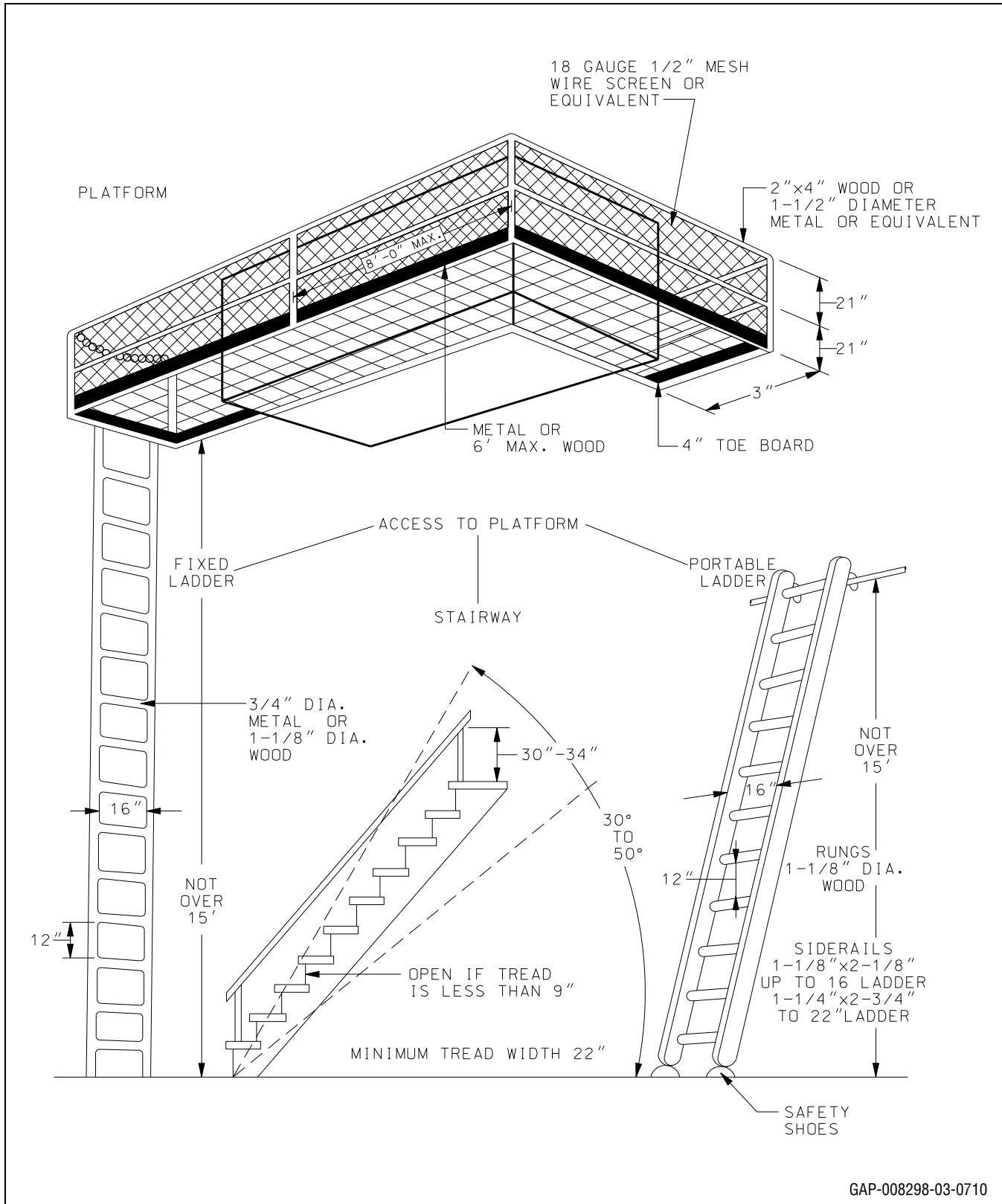

2.4 Fork Lift Platforms

See [Figure 7.3](#)

Fork lift platforms or work stages should be built to comply with all Federal and State Standards.

1. The platform should be a minimum of 36 inches x 36 inches as a preferred design.
 - a. The design working load of the platform should be calculated on the basis of a 230 lb person with 50 lb of equipment.
 - b. The platform should be made of wood, aluminum or plywood planking, steel or expanded metal. All planking should be 2 inch (nominal) scaffold grade minimum 1500 f (stress grade) construction grade lumber or equivalent.
2. Guardrails not less than 36 inches high nor more than 42 inches high should be provided with a midrail.
 - a. Wooden railings and posts should be at least 2 inch x 4 inch stock.
 - b. Pipe railings and posts should be at least 1-1/2 inch nominal diameter.
 - c. Structural steel railings and posts should be 2 inches x 2 inches x 3/8 inch angles or other metal shapes equivalent bending strength.
3. A 4 inch toeboard should be provided.
4. The platforms should be provided with a screen where persons are required to work or pass under them. The screen shall extend from the toeboard to guardrail and shall be No. 18 gage U.S. Standard wire, 1/2 inch mesh, or equivalent.
5. Means for securely attaching the platform to the lift truck should be provided.
6. The platform should be designed to fit the lift truck it is to be used with.
7. The total weight of the platform and the load should not exceed the rated lifting capacity of the lift truck.

The lift truck should not be moved in a horizontal direction while the platform is occupied.

An experienced operator should be present to operate the lift truck at all times the platform is occupied.

The customer must provide the OSHA Daily Checklist, OSHA 1910.178(q)(7), for the forklift in use. The checklist shall include inspections for:

- Engine and engine compartment
- Wheels, rims, and tires
- Forks, uprights, and attachments
- Operator controls
- Warning devices
- Fuel systems

Figure 7.3: Forklift Platforms

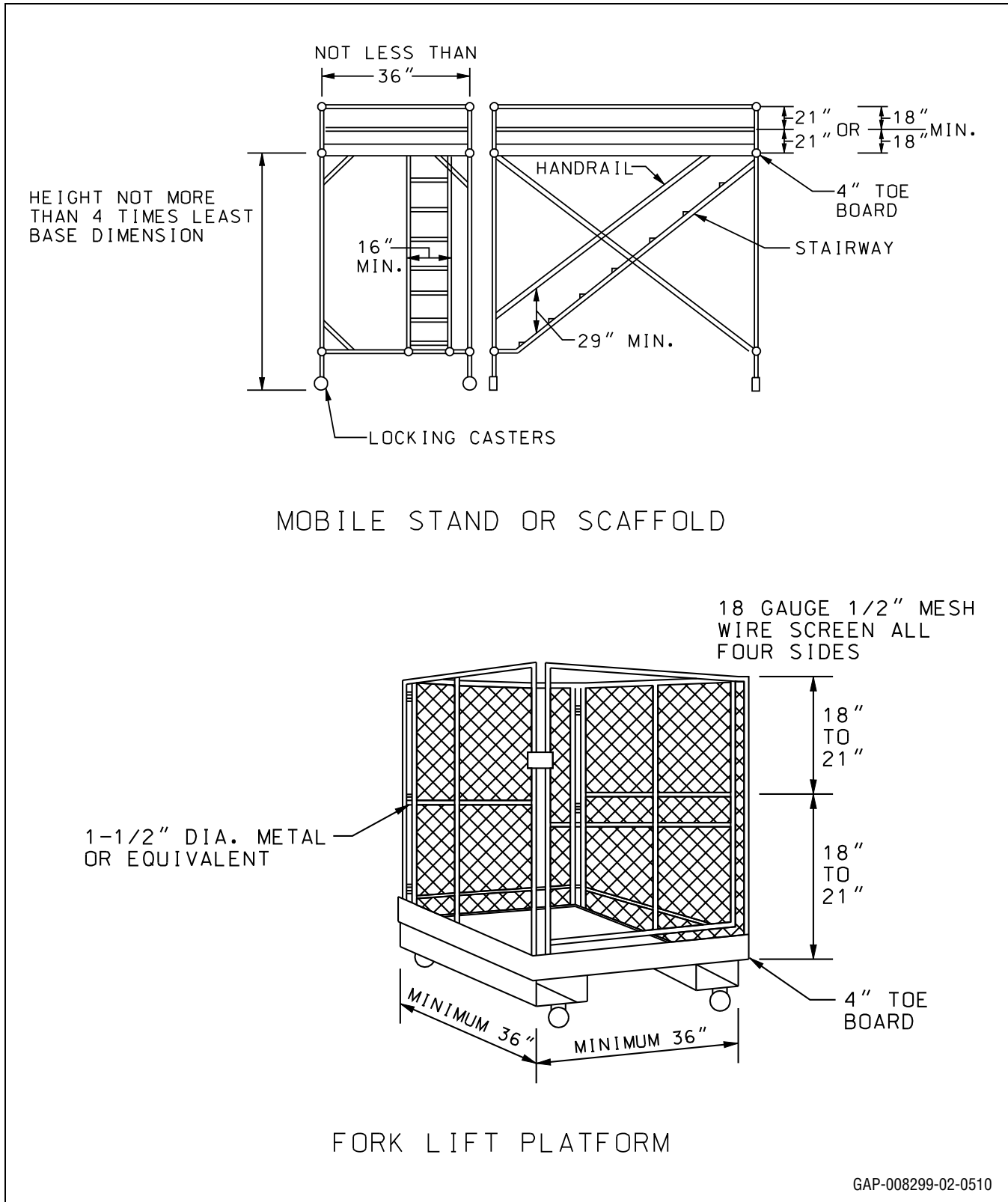

GAP-008299-02-0510

2.5 Ladders

2.5.1 Step Ladders

All step ladders should be built and used in accordance with OSHA Standard 1910.25, Portable wood ladders, and 1010.26, Portable metal ladders.

1. The maximum height should be 16 ft.
2. The minimum width between the side rails at the top step should not be less than 12 inches.

2.5.2 Portable Ladders

See [Figure 7.5](#)

All portable ladders should be built and used in accordance with OSHA Standard 1910.25, Portable wood ladders, and 1910.26, Portable metal ladders.

1. The ladder should be long enough to provide a ladder angle of one foot horizontally for every 4 ft of vertical height. See [Figure 7.4](#).
2. Non-slip safety shoes should be attached to the bottom section.
3. Hooks should be provided for attachment to ladder supports if sufficient or adequate building structural members are not present.
4. The rungs shall be spaced no more than 12 inches apart.
5. The width between side rails shall be at least 16 inches.
6. Extension ladders shall have no more than two sections.

Figure 7.4: 4 to 1 Ladder Rule

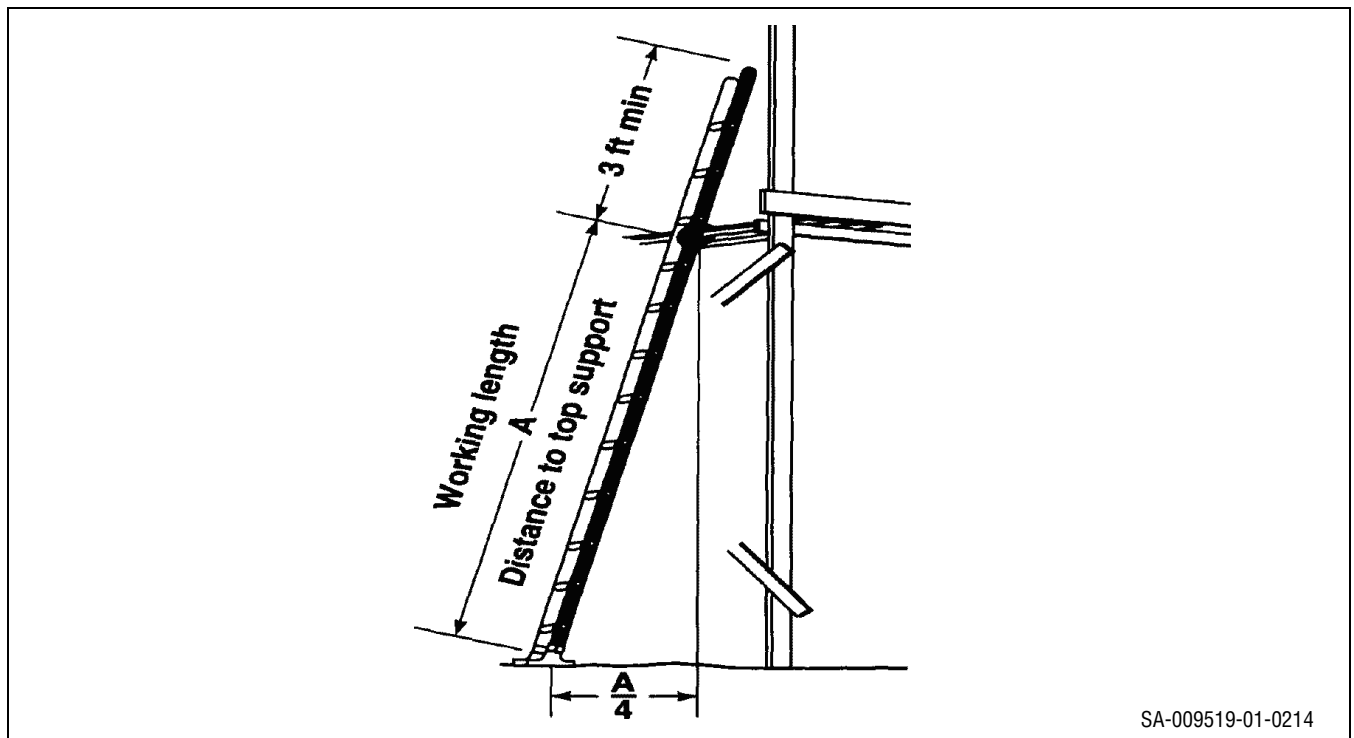

2.5.3 Platform Ladders:

All portable ladders should be built and used in accordance with OSHA Standard 1910.25, Portable wood ladders, and 1910.26, Portable metal ladders.

1. The minimum width between side rails at the platform should be less than 15 inches.
2. The back legs and side rails should extend at least 24 inches above the platform and should be connected with a top member to form a three-sided top guard rail, or equivalent construction shall be provided.
3. The platform should have an area of not less than 200 sq. inches nor more than 400 sq. inches.
4. Spreaders should be provided where the hinging apparatus is not designed to lock the unit open.
5. The slope of the front rail when the unit is in the open position should not be less than 3-1/2 inches per foot of rise, and the slope of the back section should be such that a vertical from the back edge of the platform will strike the floor at a distance, measured toward the front section, of not less than 3 inches from the base of the back section.

2.5.4 Fixed Ladders

See [Figure 7.2](#).

Fixed ladders should be constructed and used in accordance with OSHA Standard 1910.27, Fixed ladders.

1. All rungs should have a minimum diameter of 3/4 inches for metal ladders and a minimum diameter of 1-1/8 inches for wood ladders.
2. The distance between rungs, cleats and steps should not exceed 12 inches and should be uniform throughout the length of the ladder.
3. The minimum clear length of rungs or cleats should be 16 inches.
4. The distance from center line of rungs, cleats, or steps to the nearest permanent object in back of the ladder should not be less than 8 inches.
5. A clear width of at least 15 inches shall be provided measured each way from the center line of the ladder.

Figure 7.5: Portable Ladders

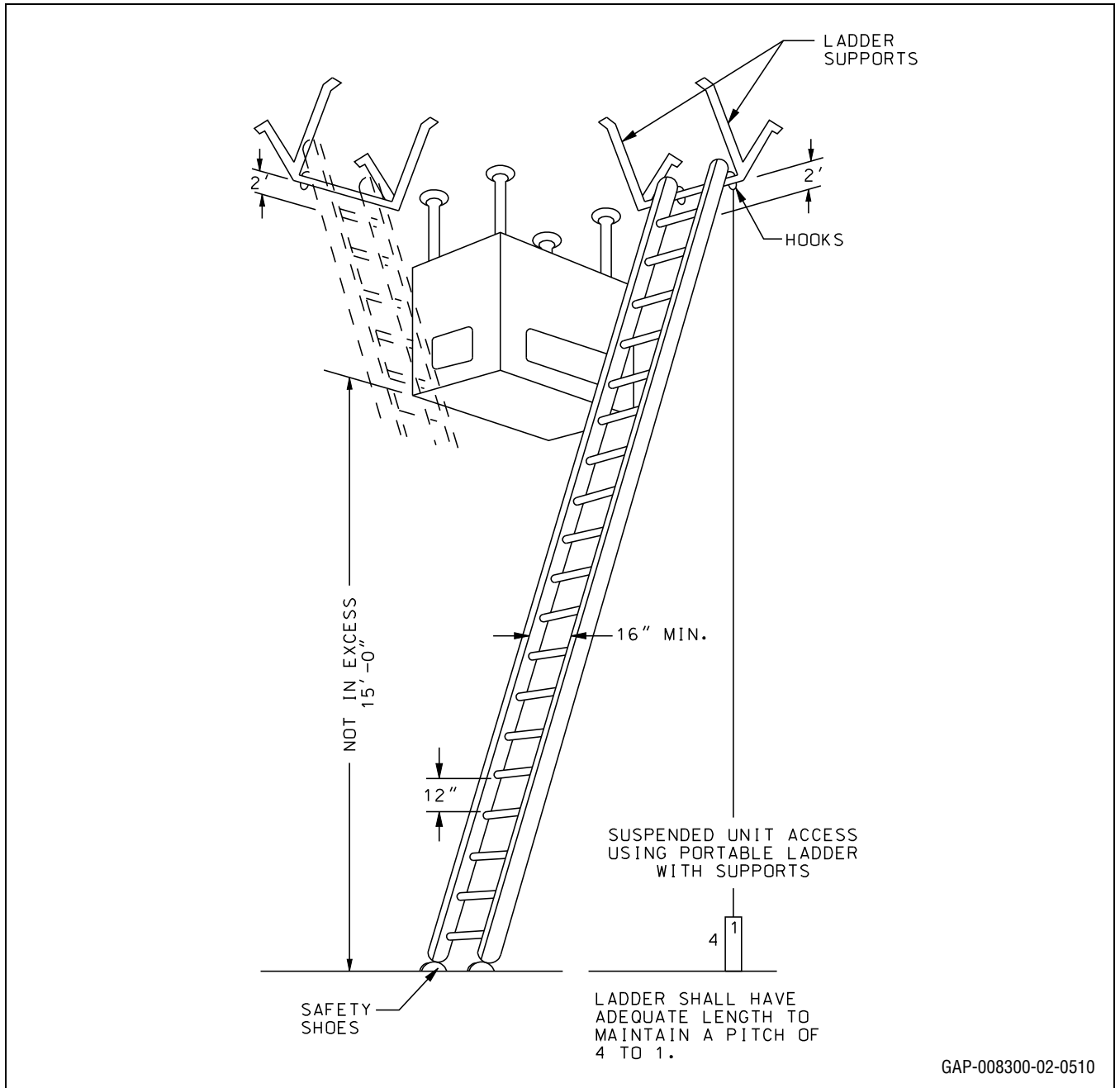
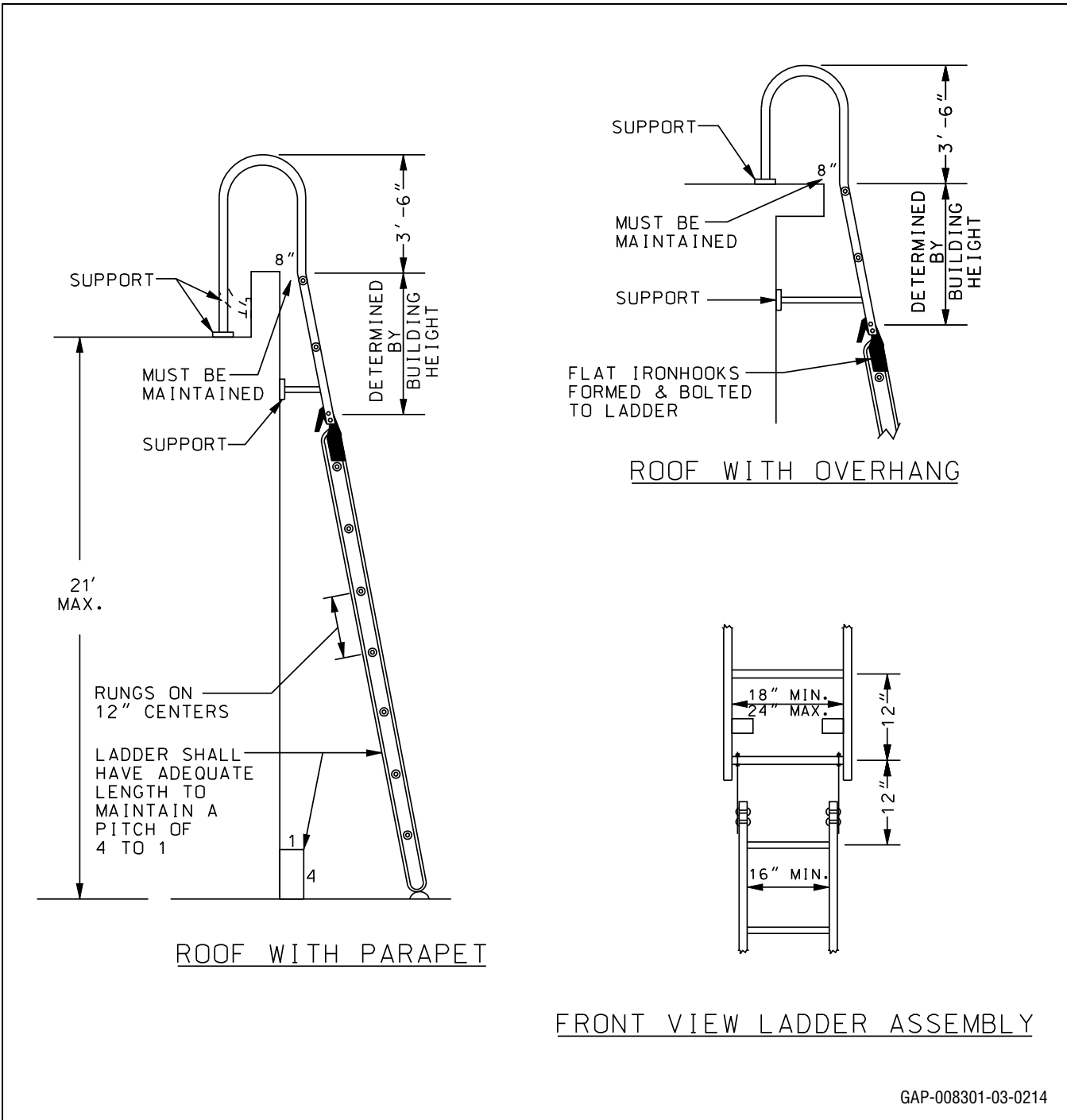

Figure 7.6: Fixed Ladders



3 Access to Appliances on Roofs

See [Figure 7.6](#), [Figure 7.7](#), [Figure 7.8](#) and [Figure 7.9](#).

A safe means of access to appliances located on roofs or other elevated locations shall be provided by the customer.

1. Access to the roofs of buildings exceeding 24 ft in height shall be provided by any one of the following methods:
 - Inside permanent or “fold-away” stairways, terminating in an enclosure, scuttle or trap door.
 - Outside stairway or ramp.
 - Inside portable ladder terminating in a scuttle or trap door if the scuttle or trap door is not more than 24 ft above the floor upon which the ladder will rest.
 - Fixed ladder that is 24 ft or less in height or meets OSHA requirement 1910.26 for ladders over 24 ft.
*Maximum height for outside fixed ladders is 30 ft, and a cage is required after 24 ft.
2. Access to the roofs of buildings not exceeding 24 ft in height shall be provided by any one of the following means:
 - Outside portable ladder.
 - Any method used in number 1 above

Scuttles or trap doors shall be at least 24 in. x 36 in. in size, and shall be constructed so as to permit access from the roof side unless deliberately locked on the inside. Construction of the means of access should comply with all Federal and State Standards. Reference may be made to the *Service Instruction Manual (SIM)*: Chapter 11 – Safety for pertinent specifications regarding OSHA rules concerning access and care and use of ladders, as well as drawings of suggested methods for complying with the provisions of Chapter 7 of this manual.

3.1 Stairways and Ramps

Stairways and ramps should be built in accordance with OSHA Standard 1910.24, Fixed industrial stairs and National Fire Protection Association No. 101, Life Safety Code.

3.2 Portable Ladders

All portable ladders should be built and used in accordance with OSHA Standard 1910.25, Portable wood ladders, and 1910.26, Portable metal ladders.

Portable ladders should be equipped with hooks at the top section for attachment to a ladder support if sufficient or adequate building structural member’s are not present to hold the ladder in a fixed position while climbing.

3.3 Caged Ladders

See [Figure 7.10](#).

Caged ladders should be constructed and used in accordance with OSHA Standard 1910.27, caged ladders.

3.4 Guard Rails

See [Figure 7.11](#).

At least 6 ft clearance should be available between the access opening and the edge of the roof or similar hazard, or rigidly fixed rails or guards at least 42 inches in height should be provided on the exposed side. A midrail should be provided halfway between the roof and top rail. A parapet or other building structure at least 42 inches in height may be utilized in lieu of guards or rails.

Figure 7.7: Outside Access to Roof Using Portable Ladders with Supports

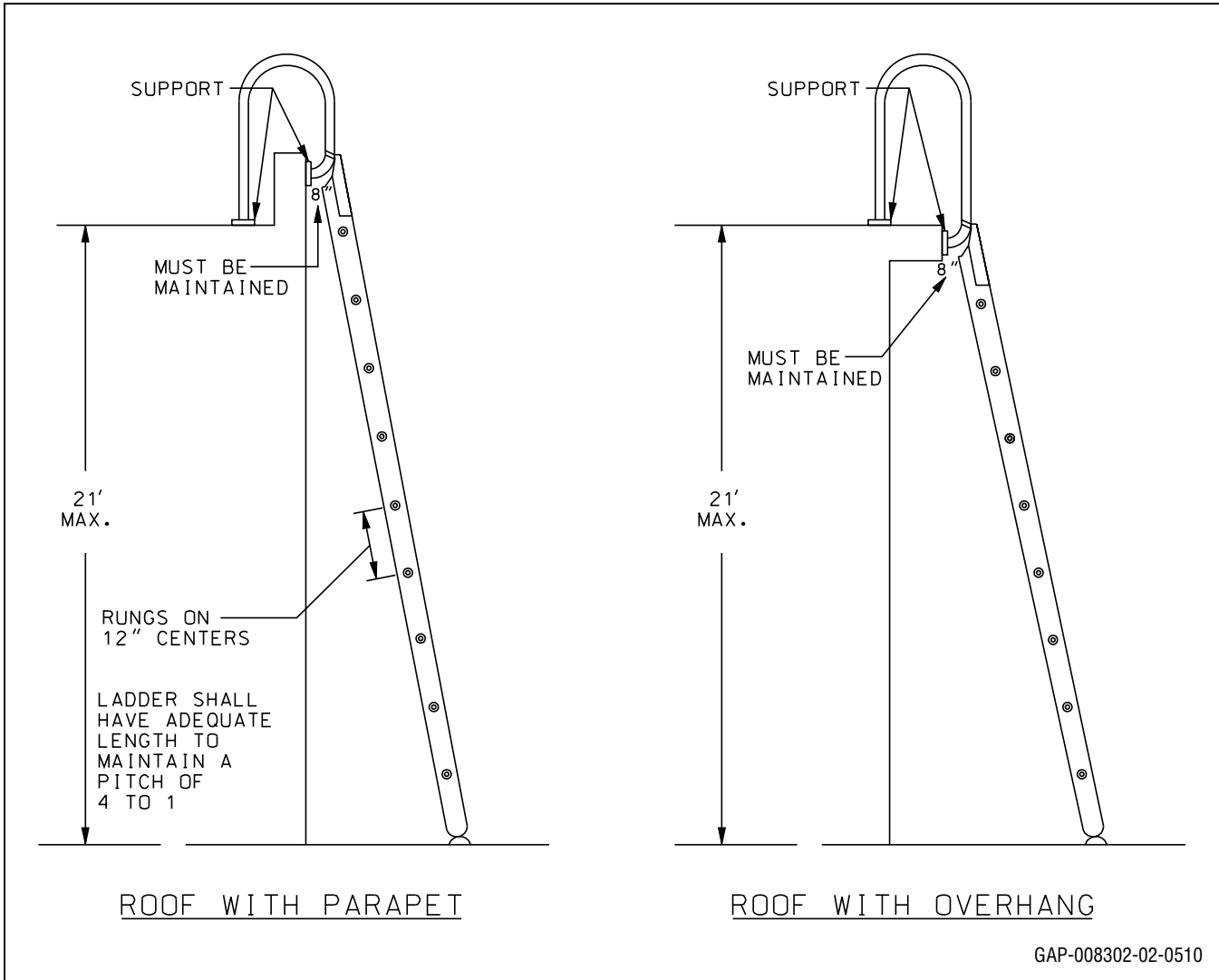

Figure 7.8: Roof Access Using Extension Ladder

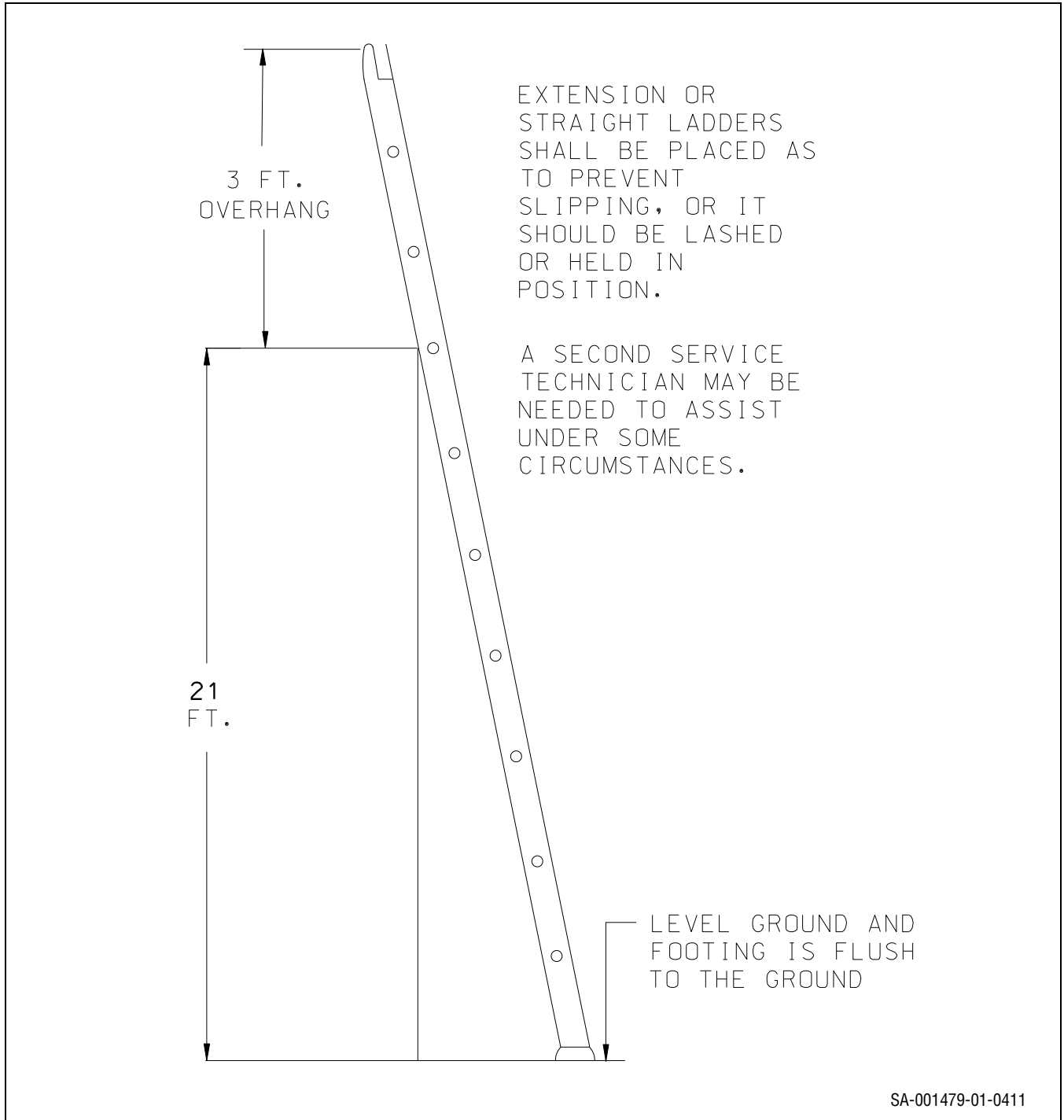

Figure 7.9: Inside Access to Roof Using Portable Ladder with Supports

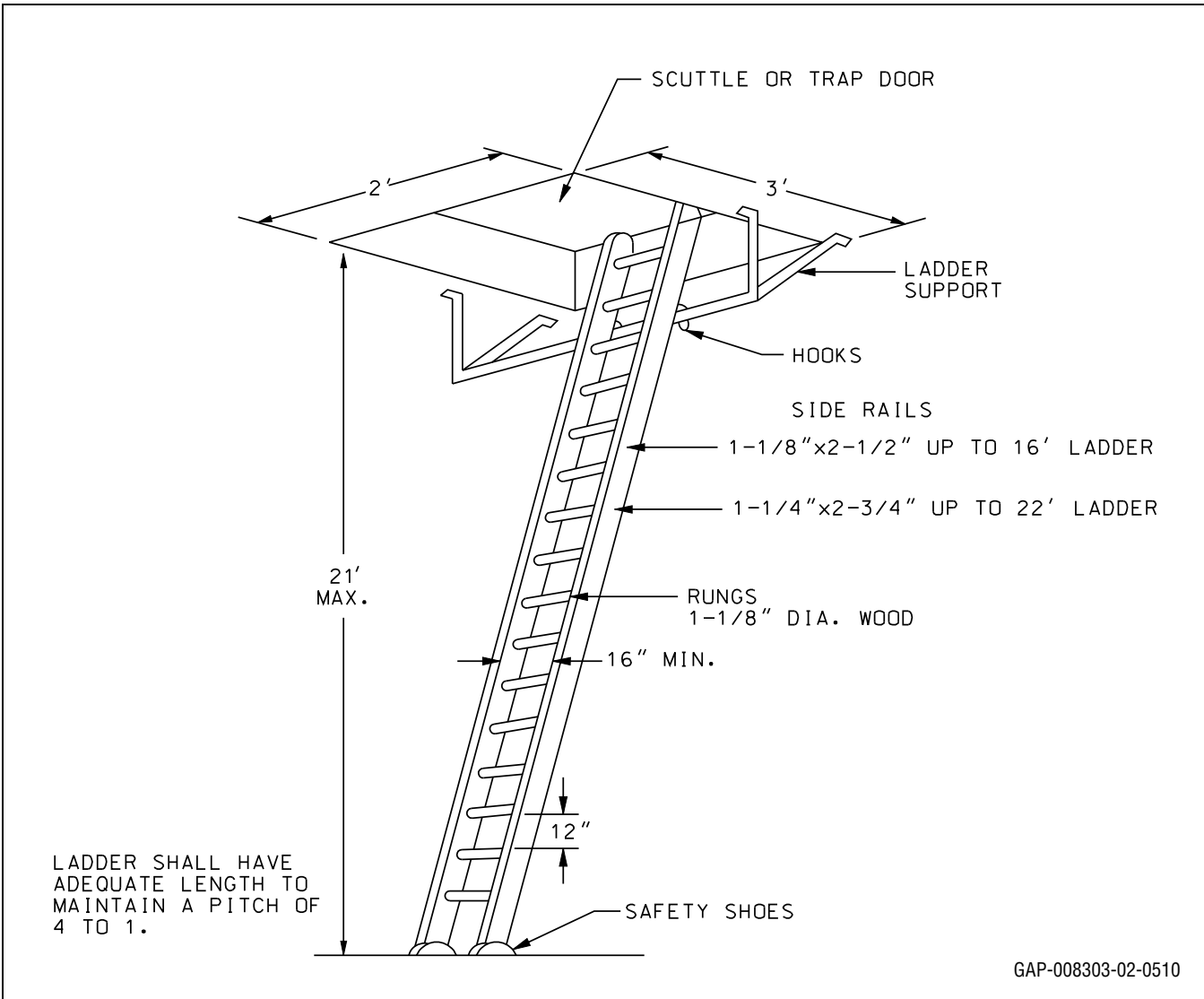

Figure 7.10: Caged Ladder

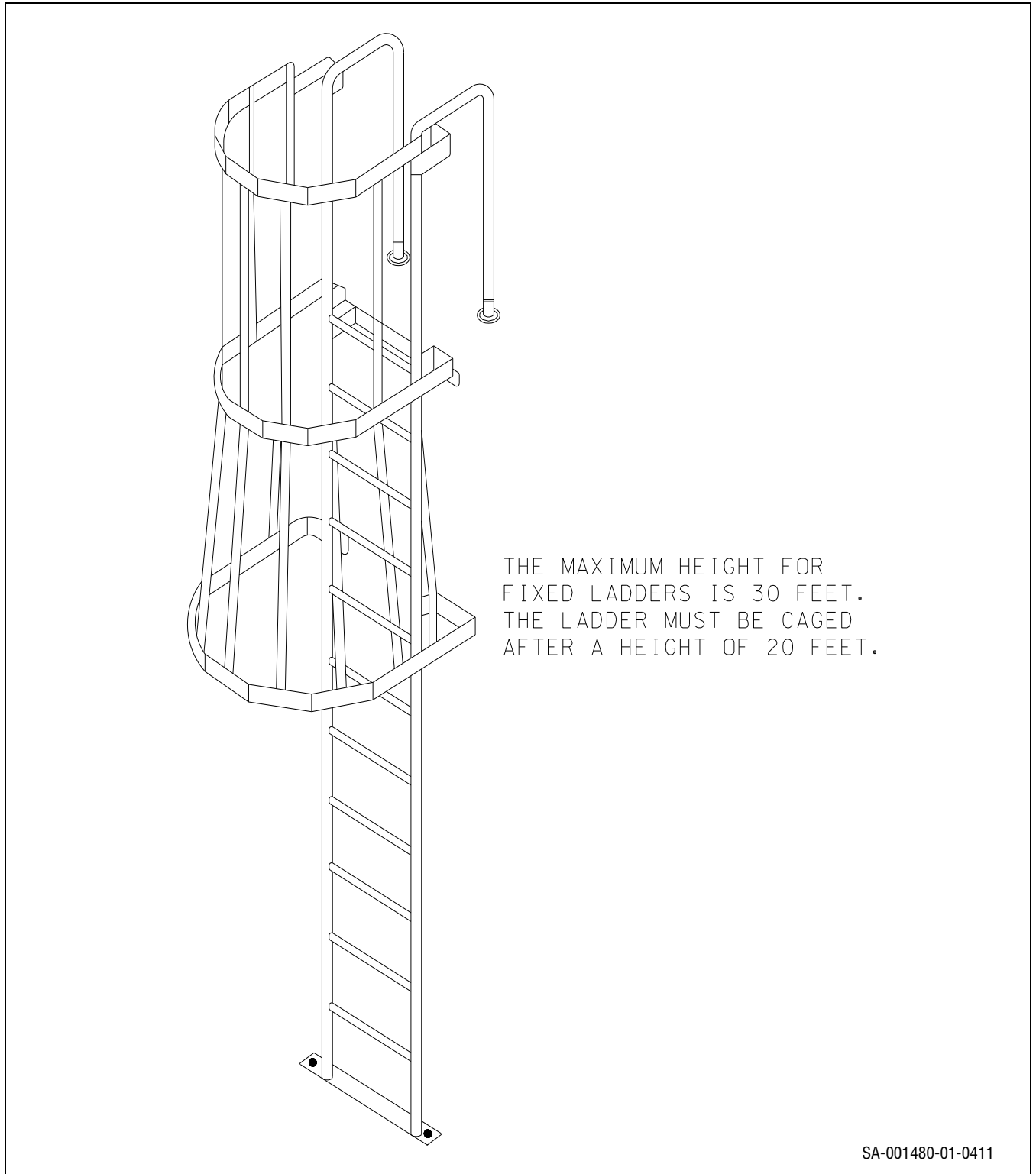
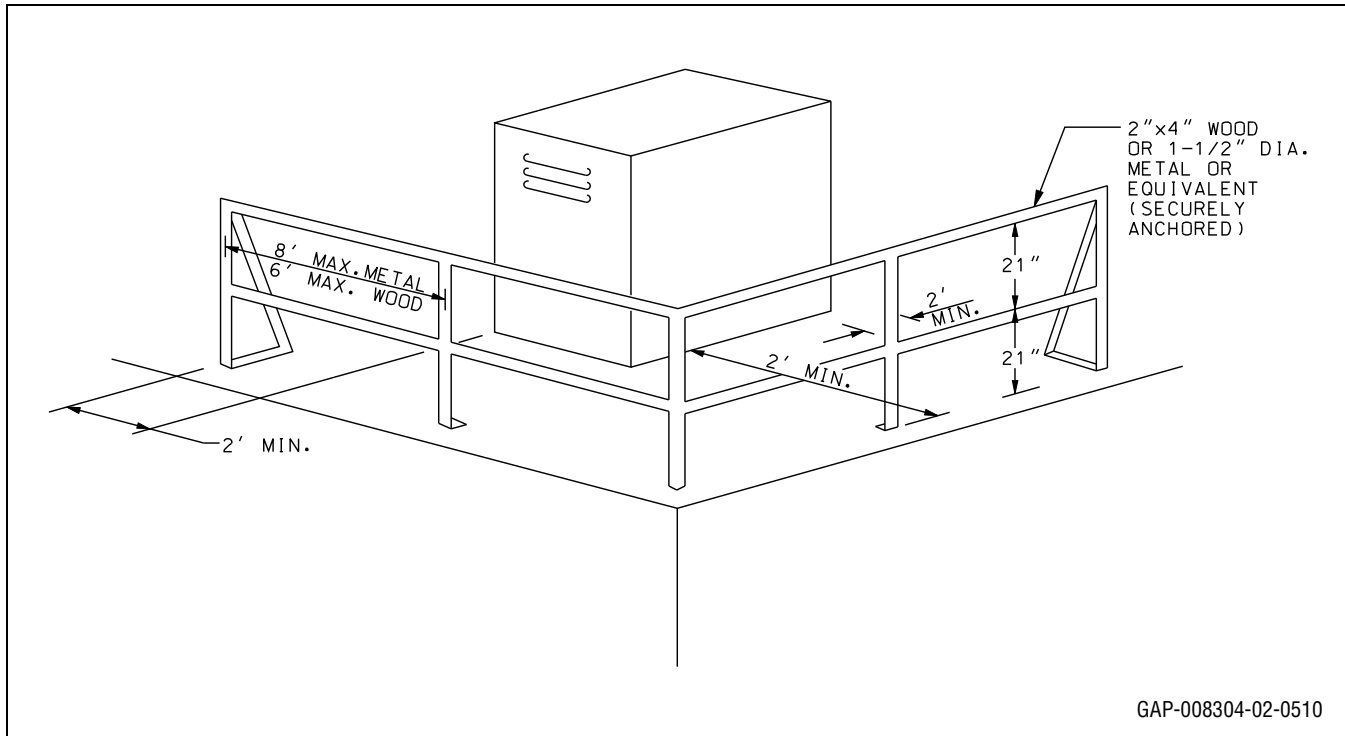

Figure 7.11: Installation on Roofs that Have No Parapet and Require Railings



3.5 Care and Use of Ladders

To ensure safety and serviceability the following precautions on the care of ladders should be observed:

1. Ladders should be maintained in good condition at all times. The joint between the steps and side rails should be tight. All hardware and fittings securely attached, and the movable parts should operate freely without binding or undue play.
2. Metal bearings of locks, wheels, pulleys, etc., should be frequently lubricated.
3. Frayed or badly worn rope should be replaced.
4. Safety feet and other auxiliary equipment should be kept in good condition to insure proper performance.
5. Ladders should be stored in such a manner as to provide ease of access or inspection, and to prevent danger of accident when withdrawing a ladder for use.
6. Wood ladders, when not in use, should be stored at a location where they will not be exposed to the elements, but where there is good ventilation. They should not be stored near radiators, stoves, steam pipes, or other places subjected to excessive heat or dampness.
7. Ladders stored in a horizontal position should be supported at a sufficient number of points to avoid sagging and permanent set.
8. Ladders should be kept with a suitable protective material.
9. Ladders should be inspected frequently and those which have developed defects should be withdrawn from service for repair or destruction and tagged or marked as "Dangerous, Do Not Use."

10. Where any of the above inspections disclose an unsafe condition, correction should be made or a replacement ladder secured before being used. The unsafe ladder should be taken out of service using the Defective Equipment Tag. (See [Figure 7.1](#))
11. Rungs should be kept free of grease and oil.

3.5.1 Safety Precautions

The following safety precautions shall be observed in connection with the use of ladders.

1. Ladders carried on vehicles shall be secured in appropriated ladder carriers.
2. Always face the ladder and grasp the rails with both hands when ascending and descending.
3. Ladders are to be used for ascending to, descending from, or working at an elevation. They are not to be used as trusses, scaffolds, etc., except in cases of emergency.
4. A ladder shall be of sufficient length to insure that the work can be done without over-reaching while standing no higher than on the third rung below the top of the ladder. Where the top support is a messenger, cross arm, etc. The ladder shall reach at least 36 inches above that support.
5. A ladder shall be so placed that both rails rest securely on a firm support. The area around the base of a ladder shall be free of hazards.
6. The safest working position for a ladder is where the horizontal distance from the bottom support to a vertical line through the top support is one-fourth of the distance between the two supports.
7. When working from a ladder extended up to 24 ft any ladder when the base or top of the ladder is insecure, it shall be securely tied as required or held by a person standing at its base and have a top stabilizer.
8. Where it is necessary to place a ladder in an area exposed to traffic, barricade or rope off the area around the ladder.
9. Before climbing a ladder, remove from shoes and gloves any substance which might cause slipping or loss of hold.
10. Only one person shall be on a ladder at any one time.
11. Always face a ladder when climbing or descending.
12. Both hands must be free and used only for support when climbing or descending a ladder.
13. Where work which requires the use of both hands is to be done from a ladder, a **safety strap shall be used**. The strap shall encircle a rung and around both rails.

Figure 7.12: Safety Belt with Two D-Rings

38523Q4-S	Safety Belt with 2 D-rings Size small	W100480	
38523Q4-M	Safety Belt with 2 D-rings Size medium	W100481	
38523Q4-L	Safety Belt with 2 D-rings Size large	W100482	
38523Q4-XL	Safety Belt with 2 D-rings Size X-large	W100483	
38523Q4-2X	Safety Belt with 2 D-rings Size 2X-large	W100484	

SA-008248-01-0214

14. A ladder must be so placed that the necessity for reaching sideways will not require a worker's shoulder to be more than 12 inches outside a rail.
15. Where the ladder is placed against a building corner, it shall be equipped with an approved top stabilizer. Where practicable, the ladder shall also be secured with ropes which can be tied to the rails before the ladder is raised.
16. When a ladder is placed against vinyl, aluminum or conventional house siding, it shall be equipped with an approved house pad to prevent dents or other damage.
17. Where the ladder is placed against a pole or column it shall be secured at the top by a rope around the pole or column and securely tied to both ladder rails. Tying the ladder to the pole or column is required whether or not the ladder is equipped with a self-centering top rung or a web grip.
18. Never overreach. Work only within convenient arms length and without leaning to right or left. Always leave one hand free and in position to grasp the ladder instantly if need arises.
19. Do not hang tools on rungs of a ladder and never carry them up a ladder unless you carry them in a tool belt. Otherwise haul tools up with a line.
20. Never climb a ladder when the rungs or shoes are slippery from mud, grease, water or other liquids. First dry them carefully and thoroughly.
21. Portable ladders used to enter an attic through a scuttle, must reach the scuttle opening.

Chapter 8 – Standardized Inspection Checklist

Table 8-1: Gas Appliance Installation Requirements

Inspection Item	References
General	
Service Entrance and Meters	PSE&G <i>Gas Distribution Standards</i> : Section 3
Gas Piping	<i>International Mechanical Code</i> : Chapter 13 and <i>International Fuel Gas Code</i> : Chapter 4
Gas Piping/Pressure Test	<i>International Fuel Gas Code</i> : Section 406
Accessibility for Service	Refer to Manufacturer's Installation instructions and <i>International Fuel Gas Code</i> : Sections 305 & 306
Manufacturer's Installation Instructions to be left on job	<i>International Fuel Gas Code</i> : Section 305.1 and Section 630.2
Venting <ul style="list-style-type: none"> • Chimney lining • Vent connector material • Vent connector size • Clearance to combustibles • Vent connector properly secured • Review Chimney maintenance with customer • Check draft hoods and double acting barometric dampers • B-vent – double wall required antics 	Refer to Manufacturer's Installation instructions. <i>International Mechanical Code</i> : Chapter 8. <i>International Fuel Gas Code</i> : Chapter 5 and Appendix B and C
Adequate Combustion Air	<i>International Mechanical Code</i> : Chapter 7. <i>International Fuel Gas Code</i> : Section 304
Electric Switch (On or Adjacent to unit)	<i>International Mechanical Code</i> : Section 306 & 1006.8, and <i>International Fuel Gas Code</i> : Section 309
Clearances Around Unit	<i>International Mechanical Code</i> : Section 306, and <i>International Fuel Gas Code</i> : Sections 306 and 308
(All appliances must be installed in accordance with the manufacturer's installation instructions. Refer to these instructions on all inspections of new equipment.)	
Forced Warm Air Heating Systems	
Plenum Clearances	<i>International Fuel Gas Code</i> : Section 308.3.4 and NFPA 90A and 90B
Approved Plenum Material	<i>International Fuel Gas Code</i> : Section 627.7
Return Duct Location	<i>International Fuel Gas Code</i> : Section 618
Return Air Ducts <ul style="list-style-type: none"> • Toxic Air • Sealed to Furnace Casing 	<i>International Fuel Gas Code</i> : Part 618.5.

Table 8-1: Gas Appliance Installation Requirements (Cont'd)

Inspection Item	References
Refrigeration Coil	<i>International Fuel Gas Code: Section 627.8</i>
Air Filters	Refer to Manufacturer's Installation Instructions
Steam Heating Systems	
Hartford Loop	Refer to Manufacturer's Installation Instructions
Header Size	Refer to Manufacturer's Installation Instructions
Equalizer	Refer to Manufacturer's Installation Instructions
Relief Valve and Piping	Refer to Manufacturer's Installation Instructions, <i>International Fuel Gas Code: Section 631</i> and <i>National Plumbing Code: Section 10.16.6</i>
Forced Hot Water Heating Systems	
Low Water Cut Off When Boiler is Installed Above Radiation	Refer to Manufacturer's Installation Instructions and <i>International Mechanical Code: Section 1007</i>
Relief Valve and Piping	Refer to Manufacturer's Installation Instructions, <i>International Mechanical Code: Section 1006</i> and <i>National Plumbing Code: Section 10.16.6</i>
Expansion Tank	Refer to Manufacturer's Instructions and <i>International Mechanical Code: Section 1009 & 1205</i>
Zone Valves • Wiring	Refer to Manufacturer's Instructions
Gas Conversion Burners	
Heating Equipment Suitable for Conversion	ANSI Z21.8 Standard for Installation of Domestic Gas Conversion Burners
Proper Burner Selection	ANSI Z21.8 Standard for Installation of Domestic Gas Conversion Burners
Installers Responsibility: • Clean Boiler • Clean Chimney	<i>International Fuel Gas Code: Section 501.15</i>
Note: Set-up to be completed by a specially equipped service person (may require a second visit)	
High Efficiency Heating Units	
Special Venting Requirements • Size • Pitch • Termination	Refer to Manufacturer's installation instructions
Condensate Drain	Refer to Manufacturer's Installation Instructions and <i>International Fuel Gas Code: Section 307</i>

Chapter 9 – PSE&G Construction Inquiry Center

Northern Counties

For Bergen, Essex, Hudson, Hunterdon, Middlesex, Morris, Passaic, Somerset and Union Counties, call 1-800-722-0256.

Southern Counties

For Burlington, Camden, Gloucester, Mercer, Monmouth and Ocean Counties, call 1-800-832-0076.

This Page Intentionally Blank

Forms

This chapter provides a list of forms used in the Gas Appliances and Gas Piping manual and links to those forms in PDF format. The PDF can be printed for hard copy use or the fillable PDF can be completed and saved. In addition, the pages following this list also contain forms that can be printed for hardcopy use.

[GS-AS-GAP-Form001](#) – Request for Higher Than Normal Pressure (for a fillable form click [here](#)).

This Page Intentionally Blank

Request for Higher Than Normal Pressure

Contacts Name: _____

Site Address: _____

Telephone Number: _____

Contractor: _____

DWMS #: _____

Equipment Make & Model: _____

Gas Pressure Required at the Burner Tip (Provide Specifications)

Gas Delivery Pressure Requested: Max CFH Normal CFH Min CFH

Size of Appliance Gas Train: _____

Note: The gas train of each appliance must meet either the customer’s insurance carrier or ANSI/PSE&G specifications, whichever has stricter requirements. Copies of the ANSI/PSE&G requirements are available at the local Gas District Headquarters.

Prior to PSE&G setting a meter, the customer shall have all equipment fitted with appliance regulators whose maximum operating pressure is higher than the approved delivery pressure; all appliance regulators must meet IFGC 410 standards. Customer’s facilities shall be designed both to prevent and to withstand the maximum failure pressure from exceeding the pressures listed in the following table.

Delivery Pressure	Design/Failure Pressure (Maximum)	Test Pressure (Minimum)
1 PSIG (CSST)	3 PSIG	3 PSIG
1 PSIG (Standard Piping)	5 PSIG	15 PSIG
Greater than 1 PSIG but not greater than 5 PSIG	Based on Design (Requires P&D Approval)	15 PSIG
Greater than 5 PSIG (Line Pressure)	Based on Design (Requires P&D Approval)	1.5 times the design pressure of the gas distribution system

COF Representative: _____

Date: _____



Gas Business Unit Reply

Gas Delivery Pressure Approved: Yes No

If Line Pressure Approved: Maximum _____ Minimum _____ Normal _____

Remarks or Reasons for Denial
